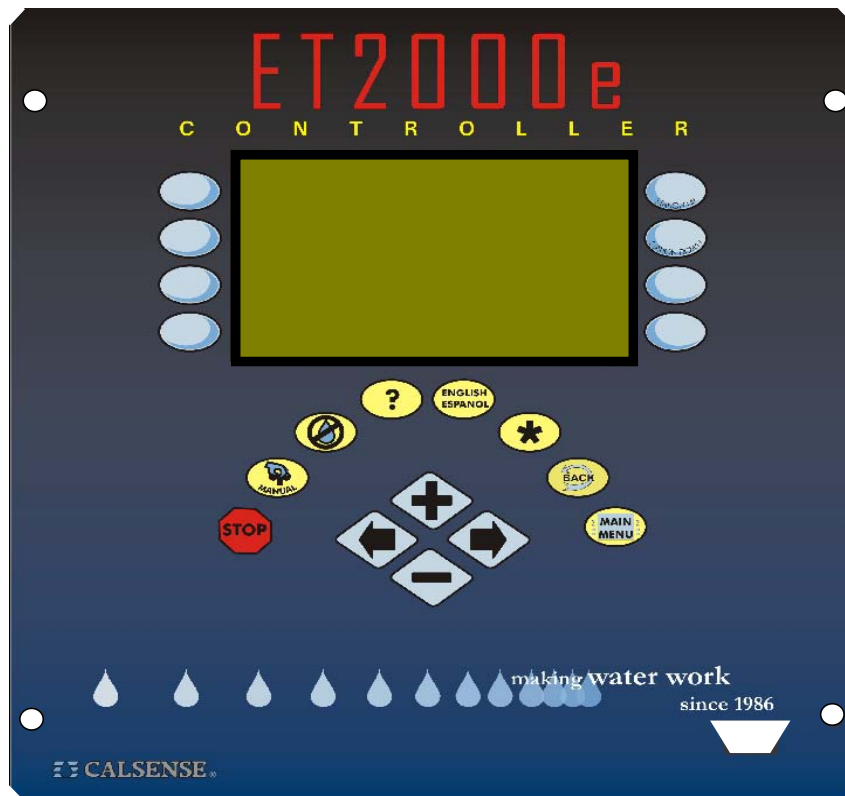


# ET2000e IRRIGATION CONTROLLER



## PROGRAMMING GUIDE

*For use with ET2000e irrigation controllers running on firmware version*

**605.a and above.**

 **TABLE OF CONTENTS**

 **SECTION 1: CONTROLLER DESCRIPTION**

- I. ET2000e KEY PAD DESCRIPTION
- II. WHAT CAN BE PROGRAMMED AT EACH SCREEN
- III. USING THIS GUIDE WITH THE ET2000e CONTROLLER

 **SECTION 2: SETUP**

- 2A. COMMUNICATIONS
  - 2A.1 CONTROLLER(S) WITH CENTRAL COMMUNICATION
- 2B. PART & SERIAL NUMBER
- 2C. DATE & TIME
- 2D. STATIONS IN USE
- 2E. 12-MONTH MODE
- 2F. ACCESS CONTROL

 **SECTION 3: PROGRAMS & STATIONS**

- 3A. START TIMES AND WATER DAYS
- 3B. STATIONS (STATION PROGRAMMING)
  - 3B.1 CYCLE AND SOAK EXAMPLES
  - 3B.2 TEST A STATION AT THE STATION PROGRAMMING SCREEN
  - 3B.3 SET NO WATER DAYS AT THE STATION PROGRAMMING SCREEN
- 3C. STATION TO STATION COPY
  - 3C.1 COPY A STATION TO ANOTHER STATION
  - 3C.2 COPY A STATION TO ALL STATIONS ON A PROGRAM, OR ALL STATIONS ON THE CONTROLLER
- 3D. PROGRAM PRIORITIES
- 3E. STATIONS BY PROGRAM
- 3F. PERCENT ADJUST
  - 3F.1 PERCENT ADJUST ALL STATIONS
  - 3F.2 PERCENT ADJUST BY PROGRAM

 **SECTION 4: FLOW**

- 4A. TRACK ESTIMATED
- 4B. POC (MV & FM)
  - 4B.1 FMBX FLOW METER SETUP
  - 4B.2 REGULAR FLOW METER SETUP
- 4C. LEARN EXPECTEDS
- 4D. LINE FILL & VALVE CLOSE TIMES
- 4E. PUMP
- 4F. MAIN LINE CAPACITY
- 4G. ON-AT-A-TIME
- 4H. FLOW CHECKING
- 4I. ALERT ACTIONS

 **SECTION 5: WEATHER**

- 5A. ET GAGE (-G OPTION)
  - 5A.1 ET GAGE SETUP
- 5B. RAIN BUCKET (-RB OPTION)
  - 5B.1 RAIN SETUP (WITH RAIN BUCKET INSTALLED)
  - 5C.1 RAIN SETUP (**WITHOUT** RAIN BUCKET INSTALLED) AND YOU ARE SHARING RAIN TO CONTROLLER
- 5C. WIND GAGE (-WG OPTION)
  - 5C.1 WIND GAGE SETUP
  - 5C.2 RESPOND TO WIND BY PROGRAM
- 5D. RAIN SWITCH
  - 5D.1 RAIN SWITCH SETUP
- 5E. ET
  - 5E.1 IRRIGATE USING ET TABLE
  - 5E.2 USE ET AVERAGING
  - 5E.3 ALLOWABLE % OF HISTORICAL ET
  - 5E.4 CROP COEFFICIENTS
  - 5E.5 STATION FLOW RATES WITHOUT A FLOW METER PRESENT
  - 5E.6 STATION FLOW RATES & AREA WITH FLOW METER INSTALLED
- 5F. BUDGET
  - 5F.1 DIRECTLY ENTER THE MONTHLY BUDGETS

5F.2 CONTROLLER WILL AUTOMATICALLY CALCULATE THE BUDGET AMOUNT USING THE TOTAL SQUARE FOOTAGE AND YOUR CITY ET

5F.3 ENTER A YEARLY BUDGET AND HAVE THE CONTROLLER DIVIDE IT AMONG THE MONTHS USING YOUR CITY ET

5G. MOISTURE

5G.1 MOISTURE SENSOR SETUP  
 5G.2 MOISTURE SENSOR ASSIGNMENT  
 5G.3 TEST MOISTURE SENSOR

5H. ET STATE / COUNTY / CITY

5H.1 ET STATE / COUNTY / CITY SETUP



**SECTION 6: REPORTS**

6A. THIS MONTH / LAST MONTH  
 6B. 24 MONTH  
 6C. HOLD-OVER  
 6D. ET AND RAIN TABLES

6D.1 REPORTS / ET & RAIN TABLE (ET)  
 6D.2 REPORTS / ET & RAIN TABLE (RAIN)

6E. ALERTS  
 6F. STATION HISTORY  
 6G. USE VS. BUDGET  
 6H. LIVE SCREENS

6H.1 IRRIGATION ACTIVITY  
 6H.2 IRRIGATION DETAILS  
 6H.3 REAL-TIME FLOW  
 6H.4 REAL-TIME POC FLOW



**SECTION 7: LIGHTS (-L OPTION)**

7A. PROGRAMMING A LIGHTS SCHEDULE  
 7B. TESTING A LIGHTS CIRCUIT



**SECTION 8: RADIO REMOTE (-RR OPTION)**

8A. ENABLE RADIO REMOTE



**SECTION 9: NO WATER KEY**

9A. NO WATER KEY DESCRIPTION

9A.1 TURN CONTROLLER OFF  
 9A.2 APPLY NO WATER DAYS TO PROGRAM  
 9A.3 NO WATER DAYS BY STATION



**SECTION 10: MANUAL KEY**

10A. MANUAL WATERING

10A.1 MANUAL WATER A STATION  
 10A.2 MANUAL WATER A PROGRAM  
 10A.3 CYCLE AND SOAK DURING MANUAL

10B. TEST

10B.1 LEARN THE EXPECTED (FLOW RATE) AT A STATION  
 10B.2 TEST A STATION  
 10B.3 TEST A STATION MOISTURE SENSOR (see SECTION 5 MOISTURE)

10C. MV (MASTER VALVE) OVERRIDE

10C.1 OPEN MASTER VALVE FOR SPECIFIED TIME  
 10C.2 WEEKLY SCHEDULE FOR OPENING MASTER VALVE

10D. LEARN EXPECTEDS (FLOW RATE)

10E. MANUAL PROGRAM 1

10F. MANUAL PROGRAM 2 (see MANUAL PROGRAM 1)

10G. WALK THRU

10H. USE HOLD OVER



**SECTION 11: FLOWSENSE® (-FL OPTION)**

11A. MULTIPLE CONTROLLER COMMUNICATION SETUP

11B. MULTIPLE CONTROLLER FLOW SETUP

11B.1 MAINLINE CAPACITY  
 11B.2 FLOW CHECKING  
 11B.3 ON-AT-A-TIME



**SECTION 12: (-F OPTION)**

12A. POINT OF CONNECTION 1 (POC 1)

12A.1 FMBX FLOW METER SETUP



- 12A.2 REGULAR FLOW METER SETUP
- 12B. POINT OF CONNECTION 2 & 3 (POC 2 & 3)
  - 12B.1 POC USE WITH IRRIGATION
  - 12B.2 POC USE WITH NON-IRRIGATION
  - 12B.3 USE MASTER VALVE FOR X.XX HOURS
  - 12B.4 SCHEDULE USE OF MASTER VALVE

 **ENCLOSURES**

1. MAXIMUM & MINIMUM SETTINGS WITHIN THE ET2000e
2. ET2000e IRRIGATION CONTROLLER SCREEN MAP
3. FLAG LETTER DEFINITION SHEET
4. STATION WIRE COLORS

---

 **CHANGES**

**SECTION 1: CONTROLLER DESCRIPTION**

II. WHAT CAN BE PROGRAMMED AT EACH SCREEN	CHANGE 1	30 MARCH 2007
---	----------	---------------

**SECTION 3: PROGRAMS & STATIONS**

3D. PROGRAM PRIORITIES	CHANGE 1	30 MARCH 2007
3F. PERCENT ADJUST	CHANGE 1	30 MARCH 2007
3F.1 PERCENT ADJUST ALL STATIONS	CHANGE 1	30 MARCH 2007
3F.2 PERCENT ADJUST BY PROGRAM	CHANGE 1	30 MARCH 2007

**SECTION 4: FLOW**

4A. TRACK ESTIMATED	CHANGE 1	30 MARCH 2007
4B. POC (MV & FM)	CHANGE 1	30 MARCH 2007
4B.1 FMBX FLOW METER SETUP	CHANGE 1	30 MARCH 2007
4B.2 REGULAR FLOW METER SETUP	CHANGE 1	30 MARCH 2007
4C. LEARN EXPECTEDS	CHANGE 1	30 MARCH 2007

**SECTION 6: REPORTS**

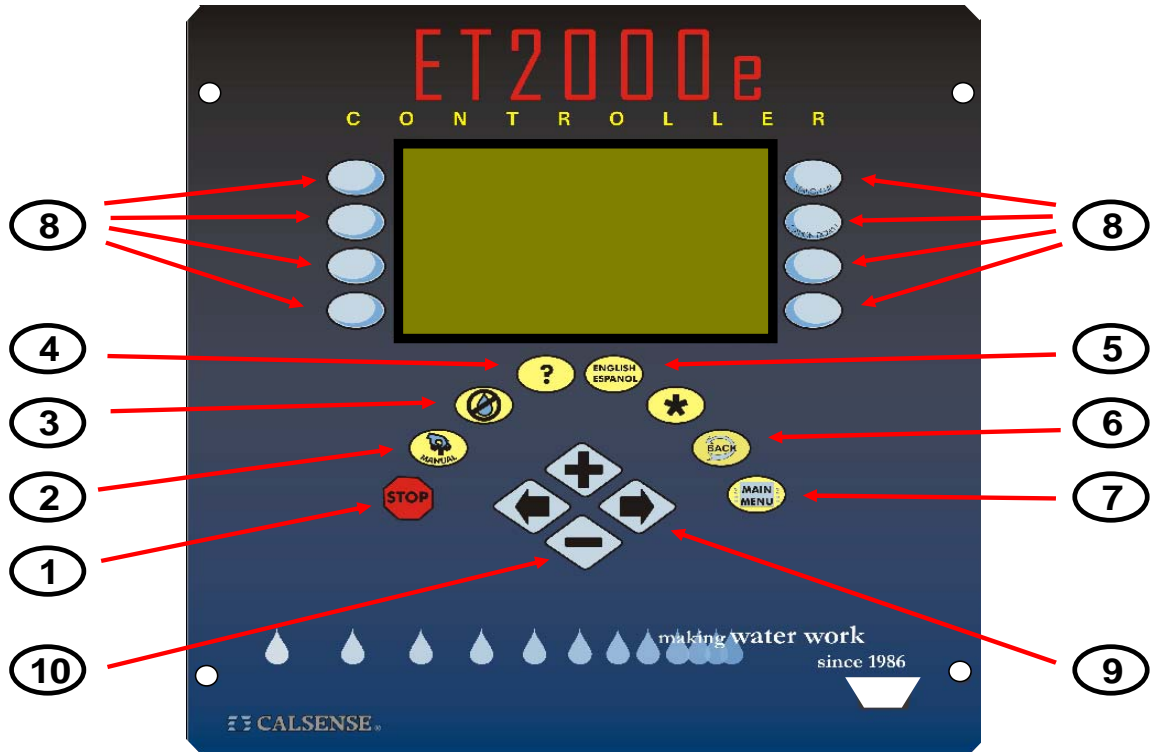
6H.4 REAL TIME POC FLOW	CHANGE 1	30 MARCH 2007
-------------------------	----------	---------------

**SECTION 12: (-F OPTION)**

12A. POC 1	CHANGE 1	30 MARCH 2007
12A.1 FMBX FLOW METER SETUP	CHANGE 1	30 MARCH 2007
12A.2 REGULAR FLOW METER SETUP	CHANGE 1	30 MARCH 2007
12B. POC 2 & 3	CHANGE 1	30 MARCH 2007
12B.1 POC USE WITH IRRIGATION	CHANGE 1	30 MARCH 2007
12B.2 POC USE WITH NON-IRRIGATION	CHANGE 1	30 MARCH 2007
12B.3 USE MASTER VALVE FOR X.XX HOURS	CHANGE 1	30 MARCH 2007
12B.4 SCHEDULE USE OF MASTER VALVE	CHANGE 1	30 MARCH 2007

**SECTION 1: CONTROLLER DESCRIPTION**

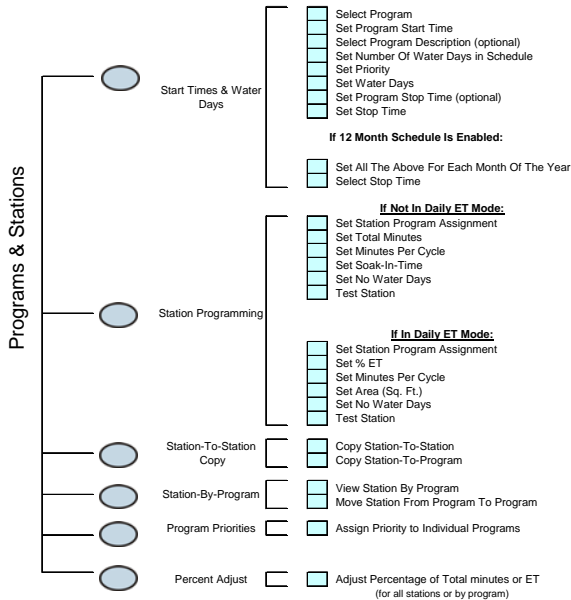
**I. ET2000e KEYPAD DESCRIPTION**



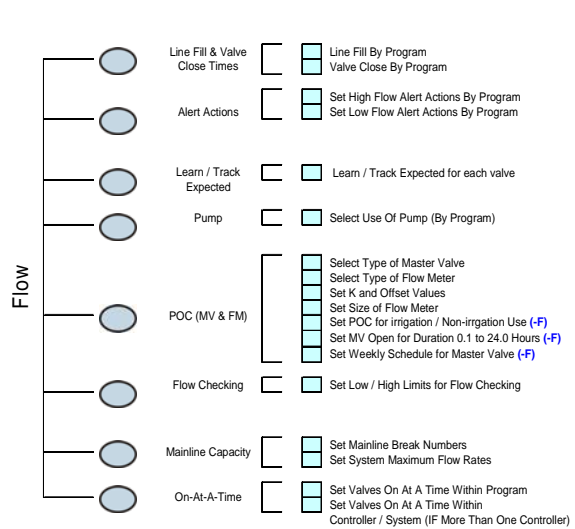
- 1 STOP** – The STOP key will stop any currently running Scheduled irrigation, Manual watering, Test Cycle, Manual Programs and lights.
- 2 MANUAL** – The MANUAL key will perform Manual Water, Station Tests, Master Valve Override, Manual Program 1 & 2, Walk-thru, and Use Hold-Over.
- 3 NO WATER** – The NO WATER key is used for turning the controller Off and to set No Water Days.
- 4 ?** – The ? key is used to access the controller Help screens.
- 5 ENGLISH / ESPANOL** – The ENGLISH / ESPANOL key allows you to toggle the screen text between English and Spanish.

- 6 BACK** – The BACK key will go back to the previous screen.
- 7 MAIN MENU** – The MAIN MENU key is used to access the various program features of the controller.
- 8 MENU KEYS** – MENU keys are used to select different features in the various screens. The text in the screen will point towards the MENU key that needs to be pressed.
- 9 LEFT/RIGHT ARROW KEYS** – The LEFT / RIGHT ARROW keys move the highlighted cursor around the screen when setting up or editing the controller's features and options.
- 10 PLUS/MINUS KEYS** – The PLUS / MINUS keys are used to change values or answer Yes or No questions in the different screens.

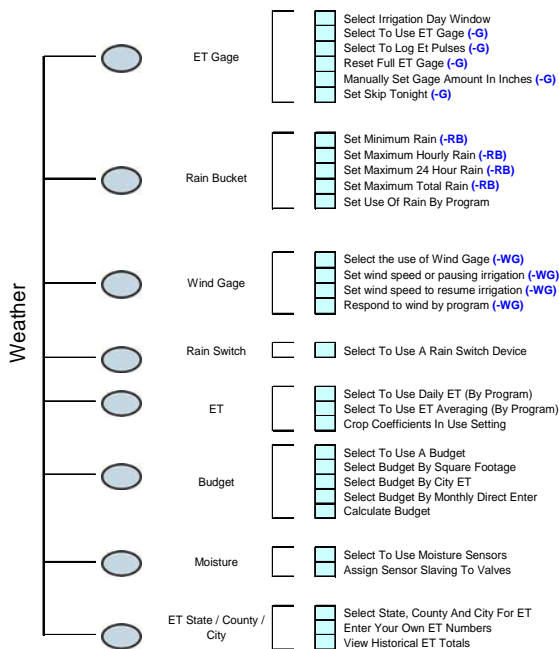
### Programs & Stations



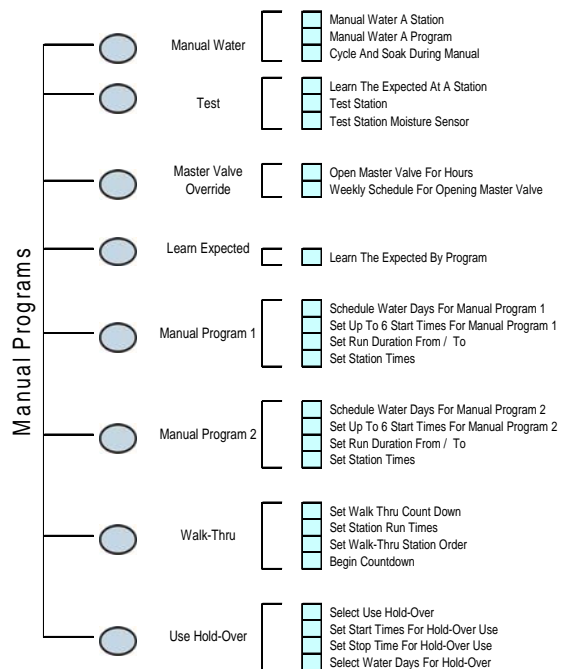
### Flow



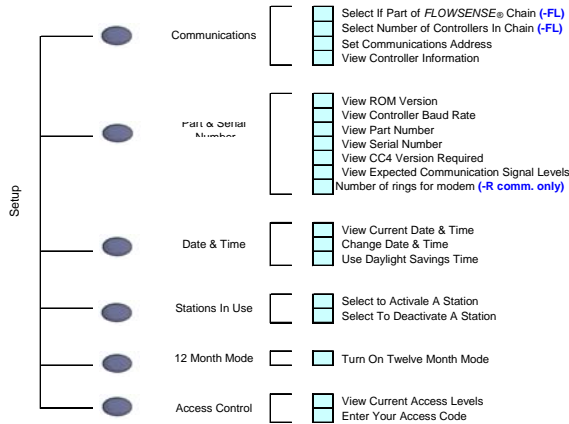
### Weather



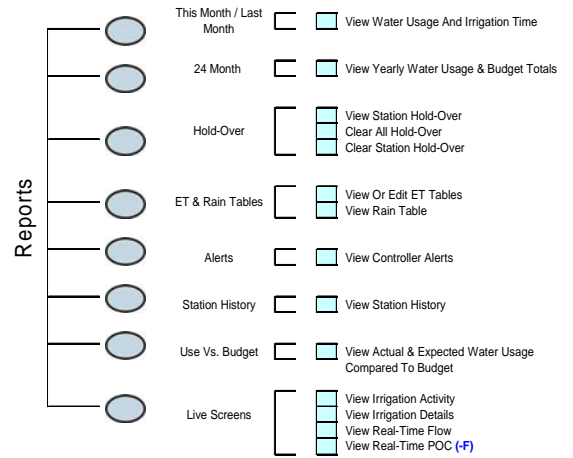
### Manual Programs



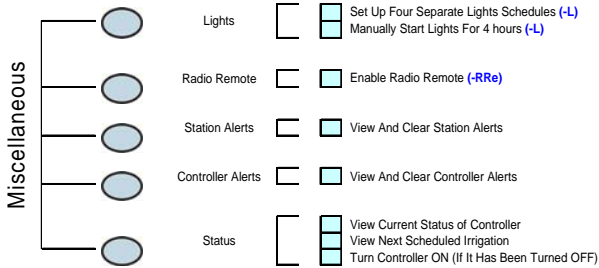
**Setup**



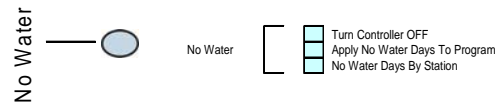
**Reports**



**Miscellaneous**



**No Water**



**III. USING THIS GUIDE WITH THE ET2000e CONTROLLER**

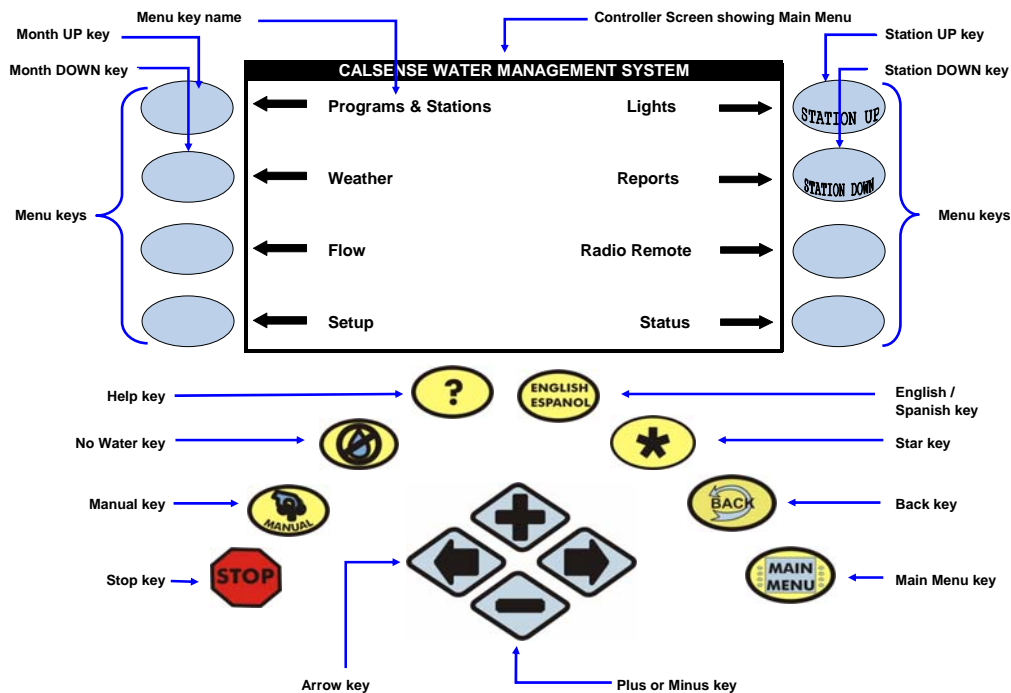
This guide explains the operation and programming of the ET2000e controller. The following describes the conventions used throughout this guide. When instructed to press a key, the name of the key will be **CAPITALIZED AND BOLD**. The illustration below shows the name and location of keys used for operating and programming the ET2000e Controller.

**MENU KEYS:** The eight (8) blue keys located on either side of the controller screen. The text next to the key indicates the choice available and will change with each screen. The arrow will point to the Menu key that is to be pressed, and the name of the key will be **CAPITALIZED AND BOLD**.

**HOT KEYS:** The eight (8) keys in a horseshoe shape directly below the display screen. They are the **STOP**, **MANUAL**, **NO WATER**, **HELP**, **ENGLISH / ESPANOL**, **STAR(\*)**, **BACK**, and **MAIN MENU** key.

**PLUS / MINUS & ARROW KEYS:** The last four (4) keys are the **PLUS** key, **MINUS** key and the two (2) **ARROW** keys. When a screen is accessed, certain information on the screen can be changed. There will be a highlighted cursor on the screen, which you can move with either **ARROW** key. A change can only be made to a setting while it is highlighted by the cursor. Once a setting is highlighted, use the **PLUS** or **MINUS** key to make the change. If the setting is a number, you can quickly scroll to the desired setting by holding down the **PLUS** or **MINUS** key.

The Controller's screen in the illustration below shows the Main Menu, which can be accessed at any time by pressing the **MAIN MENU** key. The description on the screen with the arrows, point to the Menu keys which can be pressed to access the various parts of the controller's programming (See Enclosure 1 ET2000e IRRIGATION CONTROLLER SCREEN MAP). You can always return to a previous screen by pressing the **BACK** key.



ET2000e irrigation controller key placement and description



**SECTION 2: SETUP**

The Setup section of the controller is used to access programming the following:

- Communication addresses
- Controller's Part & Serial number information
- Date & Time
- Stations in Use
- 12 month scheduling
- Access Codes



**2A. COMMUNICATIONS**

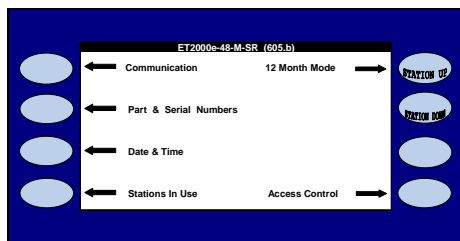
Skip communication setup section if controller(s) has no communications option installed.

The Communications screen can be used to set the communications address in the controller. This address is used for communicating back to a central computer, and is also used to differentiate one controller from another in a communications chain.

From the MAIN MENU screen:

1. Press the **SETUP** Menu key.

The SETUP screen is displayed (Figure 2.1).



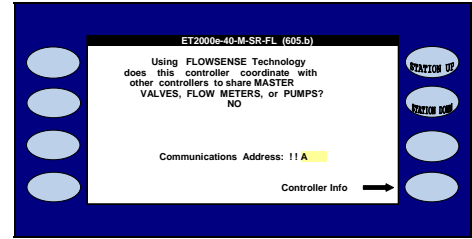
**Figure 2.1**

2. Press the **COMMUNICATION** Menu key, the COMMUNICATION screen will appear.

**2A.1 Controller(s) with central communication:**

**Note:** If **FLOWSENSE®** option is installed (this can be verified by looking for a (-FL) in the part number. (See Section 11 for detailed instructions).

The communication screen should look like the one in Figure 2.2 if your controller **does not** have the **FLOWSENSE®** option.



**Figure 2.2**

1. Press the blue **ARROW** keys to highlight the Communications Address.
2. Press the **PLUS** or **MINUS** keys to set the first character.
3. Press the blue **ARROW** keys to move the cursor to the next character.

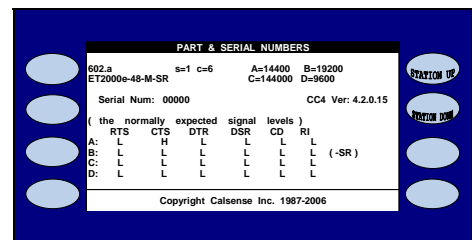
Repeat the process described above until all three characters are set (The character furthest to the right must be a letter).

**Note:** No two controllers can have the same address when communicating to the same central computer via a single central device.

**To view the controller's communications information:**

4. Press the **CONTROLLER INFO** Menu key.

The PART & SERIAL NUMBERS screen is displayed (Figure 2.3).



**Figure 2.3**

**THIS CONCLUDES THE COMMUNICATIONS SECTION**



**2B. PART & SERIAL NUMBER**

This screen contains Part & Serial Number information along with communication information for the controller.

From the MAIN MENU screen:

1. Press the **SETUP** Menu key.
2. Press the **PART & SERIAL NUMBERS** Menu key.

The PART & SERIAL NUMBERS screen is displayed (Figure 2.4).

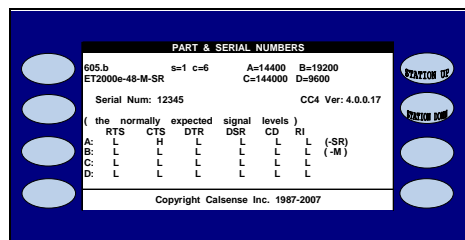


Figure 2.4

**THIS CONCLUDES THE PART & SERIAL NUMBERS SECTION**

**2C. DATE & TIME**

The Date & Time setting on a new controller will be set to Pacific Standard Time (PST) and will need to be changed to the local time by the customer upon receipt.

From the MAIN MENU screen:

1. Press the **SETUP** Menu key.
2. Press the **DATE & TIME** Menu key.

The DATE AND TIME screen is displayed (Figure 2.5).

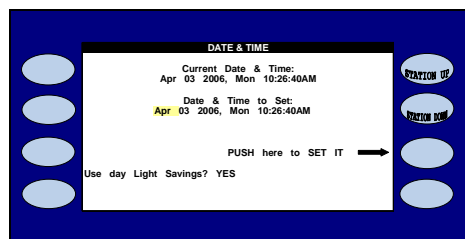


Figure 2.5

3. Press the **PLUS** or **MINUS** keys to change the Month setting.
4. Press the blue **ARROW** keys to move the cursor to the next entry.
5. Press the **PLUS** or **MINUS** keys to change the next entry. Continue on until the correct date and time are displayed.

Use this same method to highlight the "Use Daylight Saving?" entry and change it to the desired setting. If you select YES the controller will automatically change time for Daylight Saving.

6. Once you have completed this press the **PUSH HERE TO SET IT** Menu key.

**IMPORTANT:**  
The changes do not take effect until this button is pressed.

**THIS CONCLUDES THE DATE AND TIME SECTION**

**2D. STATIONS IN USE**

At this screen you can turn-off non-required station outputs. These stations will no longer be visible for programming in any other screen.

From the MAIN MENU screen:

1. Press the **SETUP** Menu key.
2. Press the **STATIONS IN USE** Menu key.

The STATIONS IN USE screen is displayed (Figure 2.6)

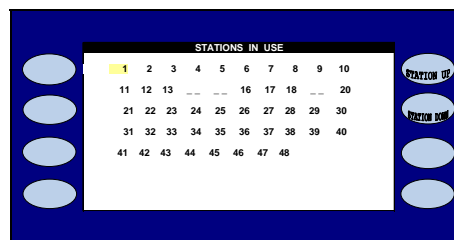






Figure 2.6

3.  To turn a station off press the blue **ARROW** keys to move the cursor to the desired station.
4.  Press the **PLUS** or **MINUS** keys to turn off the station. Two dashed lines (- -) will appear instead of the station number. (In figure 2.6, Stations 14, 15, and 19 are turned off. To turn them back on,
5.  Press the blue **ARROW** key to highlight the station.
6.  Press the **PLUS** or **MINUS** key. The station number will reappear.

**THIS CONCLUDES THE STATIONS IN USE SECTION**



 **2E. 12 MONTH MODE**

The 12 Month Mode feature allows you to pre-program an irrigation schedule for each month of the year. Each month can be programmed with different Start Times, Water Days, Number of Days in Schedule, Total Minutes, Minutes per Cycle and Soak In Time.

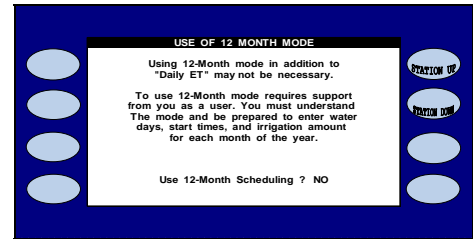
**Note:** A 12 month schedule is not required to water all year around.

**Note:** The first time 12 Month Mode is enabled, the controller will copy the current irrigation schedule to all twelve months of the year. All of the months will keep this schedule until you re-program each month's schedule. If you enable 12 Month Mode before the controller has been programmed with an irrigation schedule, there will be no Start Times, Water Days or Run Times on all twelve months of the year. Be sure an irrigation schedule has been programmed for all twelve months of the year.


From the MAIN MENU screen:

1.  Press the **SETUP** Menu key.
2.  Press the **12 MONTH MODE** Menu key.

The USE OF 12 MONTH MODE screen is displayed (Figure 2.7)



**Figure 2.7**

3.  Press the **PLUS** or **MINUS** key to change the setting.



If you select YES, you will have to return to the START TIMES & WATER DAYS and STATIONS screens and enter the information for each month accordingly. To scroll between months, press the upper-most blue Menu key on the left hand side of the screen.

**THIS CONCLUDES THE 12 MONTH MODE SECTION**

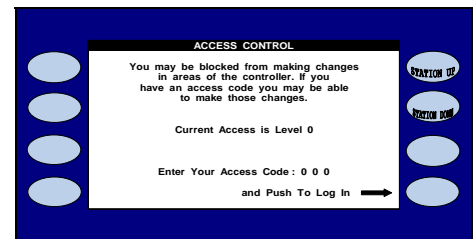
 **2F. ACCESS CONTROL**

Using the Calsense Command Center software, a three character password can be sent to the controller for up to 10 users. Once a password has been sent, the user will only be able to make changes to screens the operator has given him access to via the password entered by the user at the ACCESS CONTROL screen.




From the MAIN MENU screen:

1.  Press the **SETUP** Menu key. The SETUP screen will appear.
2.  Press the **ACCESS CONTROL** Menu key.

The ACCESS CONTROL screen is displayed (Figure 2.8).



**Figure 2.8**

3.  Enter the first character of the password by pressing the **PLUS** or **MINUS** key until the character appears.
4.  Press the blue **ARROW** keys to move the cursor to the next character, repeat the process described above until all three password characters appear.
5.  Press the **PUSH TO LOG IN** Menu key. A message will appear confirming that the log in was successful and the LOG OUT prompt will appear.

**Note:** Access Control Codes are set up and sent using **Command CENTER** software.

**Note:** Any screen blocked from use by Access Control Codes will issue an advisory to the user, and block any programming changes that particular screen.

### THIS CONCLUDES THE ACCESS CONTROL SECTION

## SECTION 3: PROGRAMS & STATIONS



The Programs & Stations section of the controller is used for programming or viewing the following:

- Start Times & Water Days
- Individual station programming
- Copy Station to another Station or Program
- Viewing stations by program
- Assign Program Priorities
- Adjust stations or programs by a percentage

### 3A. START TIMES & WATER DAYS

The Start Times & Water Days section of the controller is used to setup individual program start times, program name (optional), number of days in a schedule, individual program priorities, schedule days, and stop times.

From the Main MENU screen:

1.  Press the **PROGRAMS & STATIONS** Menu key.
2.  Press the **START TIMES & WATER DAYS** Menu key.

The START TIMES & WATER DAYS screen is displayed (Figure 3.1).

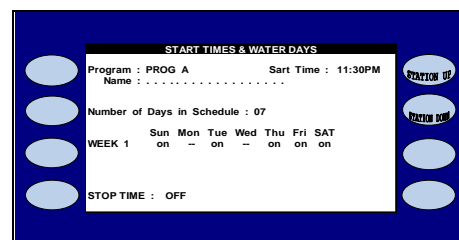





Figure 3.1

3.  Press the blue **ARROW** keys to move the cursor to the setting you wish to change.
4.  Press the **PLUS** or **MINUS** keys to change the highlighted setting.

5.  When at the **START TIMES & WATER DAYS** screen, the two (2) top right Menu keys can be used to scroll to the different programs. The following explains each setting on the **START TIMES & WATER DAYS** screen.
- **PROG:** Indicates the current program. Program A is being programmed in the example Figure 3.1. The ET2000e Controller has seven (7) programs A, B, C, D, E, Drip1, and Drip 2.
  - **START TIME:** The Start Time for scheduled irrigation on the current program. Program A has a 11:30 PM Start Time.
  - **NAME:** A program description can be selected which describes the type of plant material and irrigation heads assigned to that program (this setting is optional).
  - **DAYS IN SCHEDULE:** The ET2000e can be set with a 7-Day schedule (shown in Figure 3.1), 14-Day Schedule, 21-Day Schedule or 28-Day Schedule.
  - **PRIORITY:** Allows the user to assign which program takes precedence over another. This will only take affect when more than one program irrigates at, or during the same time.
  - **WATER DAYS:** The days of the week in the schedule to irrigate. "on" represents a water day, "-" represents an off day. The day in capital letters designates today.
  - **STOP TIME:** A time at which irrigation is forced to end, even if the scheduled irrigation cycle is not finished.

**THIS CONCLUDES THE START TIMES & WATER DAYS SECTION**



 **3B. STATIONS (STATION PROGRAMMING)**

The stations section of the controller is used to setup the following:

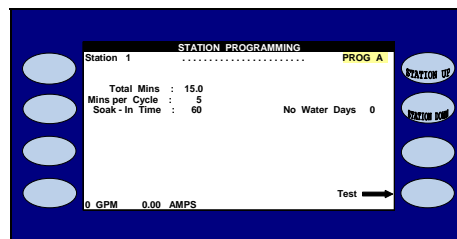
- Individual station program assignments
- Total minutes (if **not** in Daily ET)
- Minutes per Cycle
- Soak-In Times
- No Water Days
- % of ET (if in Daily ET mode)
- Expected Flow Rates (if in Daily ET mode, or Budgets in use)
- Area square footages (if in Daily ET mode)
- Precipitation Rates (if in Daily ET mode)

**Note:** Station descriptions can be entered via the **Command CENTER** software and will appear on the screen as well.



From the MAIN MENU screen:

1.  Press the **PROGRAMS & STATIONS** Menu key.
2.  Press the **STATIONS** Menu key.

The **STATION PROGRAMMING** screen is displayed (Figure 3.2).



**Figure 3.2**

3.  Press the blue **ARROW** keys to move the cursor to the setting you want to change.
4.  Press the **PLUS** or **MINUS** keys to change the highlighted setting.

5. When at the Station Programming screen, the two (2) top right Menu keys are used for **STATION UP** and **STATION DOWN**. The following explains each setting on the STATION PROGRAMMING screen.
- **STATION:** Indicates the current station number (Station 1 is the example in figure 3.2).
  - **PROG:** Indicates the program that the current station is assigned to (Program A is the example in figure 3.2).
  - **TOTAL MINS:** The total amount of irrigation time that will be applied in each 24 our watering period.
  - **MINS PER CYCLE:** The amount of irrigation time applied in each cycle of a 24 hour watering period.
  - **SOAK-IN TIME:** The amount of time (In Minutes) between multiple cycle starts.

**3B.1 Cycle and soak examples:**

In the example shown in figure 3.2, station 1 will irrigate for 5.0 minutes (the Mins per Cycle setting) then wait 60 minutes (the Soak-in Time setting), it will repeat the process two (2) more times until the total irrigation applied is 15 minutes ( the Total Mins setting), this feature is called Cycle and Soak. Each station's Cycle and Soak setting can be set independent of any other station's settings. The following shows some examples of Cycle and Soak settings:

Example 1

**Total Mins:** 10.0  
**Mins per Cycle:** 2.0  
**Soak-in Time:** 15

In this example the controller will irrigate 5 cycles of 2 minutes, for a total of 10 minutes with a soak in time of 15 minutes between cycles.

Example 2

**Total Mins:** 10.0  
**Mins per Cycle:** 10.0  
**Soak-in Time:** 5.0

In this example the total minutes and the minutes per cycle are the same, therefore the controller will irrigate only one cycle of ten minutes. **The soak in time will be ignored.**

Example 3

**Total Mins:** 10.0  
**Mins per Cycle:** 20.0  
**Soak-in Time:** 10

In this example the controller will irrigate 1 cycle of 10 minutes. **The Mins per Cycle Time and Soak-In Time will be ignored.**

**3B.2 Test a Station at the Station Programming Screen**

1. Press the **TEST** Menu key to turn the current station on. The run time will be the time set at the Valve Testing screen.
2. Pressing the **STOP** key at anytime will end the test.

**3B.3 Set No Water Days at the Station Programming Screen**

No Water Days gives you the ability to turn a specific station off for a certain amount of days consecutively starting from today's date. This setting will only affect the station selected on the screen.

1. To turn the current station off for 1 to 31 days, press the blue **ARROW** keys to highlight the No Water Day setting.
2. Press the **PLUS** or **MINUS** keys to set the number of No Water Days desired.

**THIS CONCLUDES THE STATION PROGRAMMING SECTION**



**3C. STATION-TO-STATION COPY**

The Station to Station Copy feature allows you to copy programming from one station to another station, all stations, or all of the stations in a particular program.

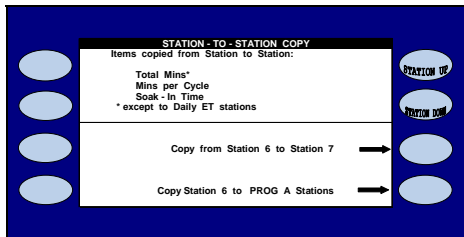
The settings that are copied are:

- Total Minutes (except in Daily ET mode)
- Minutes Per Cycle
- Soak-In Time

From the MAIN MENU screen:





1.  Press the **PROGRAMS & STATIONS** Menu key.
2.  Press the **STATION – TO – STATION COPY** Menu key.

The STATION TO STATION COPY screen is displayed (Figure 3.3).






**Figure 3.3**

**3C.1 Copy a Station to another Station**

1.  At the Station-To-Station Copy screen press the **PLUS** or **MINUS** key until the station you want to copy to is highlighted. (Station 7 is selected in Figure 3.3).
2.  Press the blue **ARROW** keys to highlight the station you want to copy from. (Station 6 is selected in Figure 3.3)
3.  Press the **PLUS** or **MINUS** keys to change the station to copy to.
4.  Press the **COPY FROM STATION TO STATION** Menu key. The station will be copied and you will be asked to press any key to continue.

**3C.2 Copy a Station to All Stations on a Program, or All Stations on the Controller:**

1.  At the STATION-TO-STATION COPY screen press the blue **ARROW** keys to move the cursor.



2.  Press the **PLUS** or **MINUS** key to select all stations or a specific program.
3.  Press the **COPY STATION x TO PROG x** Menu key. The station will copy and you will be asked to press any key to continue.

**THIS CONCLUDES THE STATION TO STATION COPY SECTION**

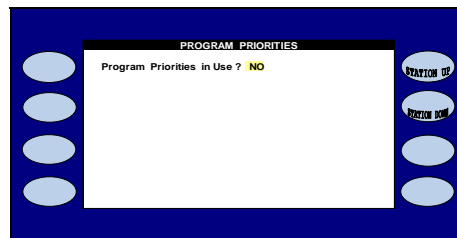
 **3D. PROGRAM PRIORITIES**

Allows the user to assign a preference as to which program takes precedence over another. This will only take affect when more than one program irrigates at, or during the same time.


From the MAIN MENU screen:

1.  Press the **PROGRAMS & STATIONS** Menu key.
2.  Press the **PROGRAM PRIORITIES** Menu key.

The PROGRAM PRIORITIES screen is displayed (Figure 3.4).



**Figure 3.4**

3.  Press the **PLUS** or **MINUS** keys to change the PROGRAM PRIORITIES IN USE? to YES.

**Note:** When set to **NO** the controller will follow regularly scheduled irrigation parameters.

The PROGRAM PRIORITIES screen will change to reveal the program settings (Figure 3.5).

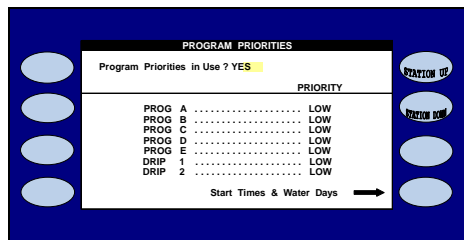


Figure 3.5

4. Press the blue **ARROW** keys to highlight the program you want to set a priority for.
5. Press the **PLUS** or **MINUS** keys to change the program priority.

**Note:** If two or more programs are set to exactly the same parameters, priority level, and irrigate at or during the same time period: they will ignore Program Priority settings and follow regularly scheduled irrigation parameters.

- **LOW:** This is the lowest setting of the three and has the least priority.
- **MEDIUM:** This is the intermediate setting of the three priorities.
- **HIGH:** This setting has precedence over the other two settings

6. Press the **START TIMES & WATER DAYS** Menu key to view **START TIMES & WATER DAYS** screens for each program.

**THIS CONCLUDES THE PROGRAM PRIORITIES SECTION**

### 3E. STATIONS-BY-PROGRAM

This section of the controller allows you to view each station, by program, that it is currently assigned to. You can also move individual stations from one program to another.

1. At the **PROGRAMS & STATION** screen press the **STATIONS-BY-PROGRAM** Menu key.

The **PROGRAM ASSIGNMENT SUMMARY** screen is displayed (Figure 3.6).

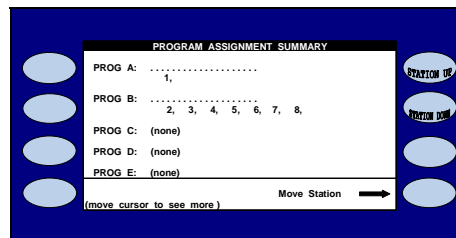


Figure 3.6

2. Press the **PLUS** or **MINUS** keys to scroll through the programs.
3. Press the blue **ARROW** keys to highlight the station that you want to move.
4. Press the **MOVE STATION** Menu key.

The **CHANGE STATION PROGRAM ASSIGNMENT** screen is displayed (Figure 3.7)

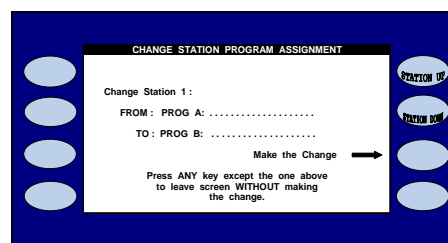


Figure 3.7



5. Press the **PLUS** or **MINUS** keys to change the program.
6. Press the **MAKE THE CHANGE** Menu key to change the station to its new program.



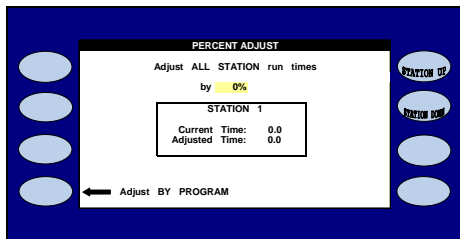
**3F. PERCENT ADJUST**

Percent Adjust allows the user to adjust the Total Minutes or % of ET used by every station, or by program by a specific percentage.

From the MAIN MENU screen:


1.  Press the **PROGRAMS & STATIONS** Menu key.
2.  Press the **PERCENT ADJUST** Menu key.

The PERCENT ADJUST screen is displayed (Figure 3.8).

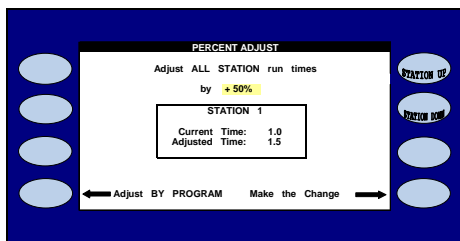


**Figure 3.8**

**3F.1 Percent Adjust ALL STATIONS**


1.  Press the **PLUS** or **MINUS** keys to change the "ADJUST ALL STATIONS".

**Note:** If this entry is changed to any value other than zero the MAKE THE CHANGE Menu key will be displayed (Figure 3.9).




**Figure 3.9**

**Note:** You can view what impact your change will have on each particular station by using the **STATION UP** or **STATION DOWN** Menu keys located to the right of the display screen.

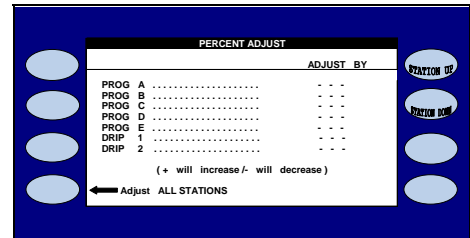
2.  Press the **MAKE THE CHANGE** Menu key.

**3F.2 Percent Adjust BY PROGRAM**


From the PERCENT ADJUST screen (Figure 3.8).

1.  Press the **ADJUST BY PROGRAM** Menu key.


The PERCENT ADJUST screen is displayed (Figure 3.10).



**Figure 3.10**

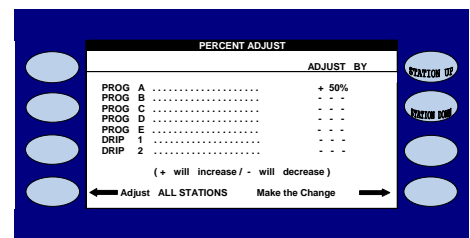
2.  Press the blue **ARROW** keys to highlight the Program Percentage that you want to change.

**Note:** The Adjust by Percentage range will show as three dashes if set to zero and can be adjusted from decrease by 99% to increase by 200%.


3.  Press the **PLUS** or **MINUS** keys to change the percent setting.

Repeat to change each individual program.

**Note:** If any entry is changed to any value other than zero the MAKE THE CHANGE Menu key will be displayed (Figure 3.11).



**Figure 3.11**

4.  Press the **MAKE THE CHANGE** Menu key.


**THIS CONCLUDES THE PERCENT ADJUST SECTION**

## SECTION 4: FLOW

The Flow section of the controller is used for setting up the following:

- Line Fill & Valve Close Times
- Alert Action settings
- Track Estimated / Learn Expected by Program
- Pump Use by Program
- Master Valve/Flow Meter type, size, and K & Offset values.
- Flow Checking parameters
- System Capacity parameters
- Valve On-at-a Time settings

From the MAIN MENU screen:

1.  Press the **FLOW** Menu key.

The FLOW METER, MASTER VALVE & PUMP screen is displayed (Figure 4.1).

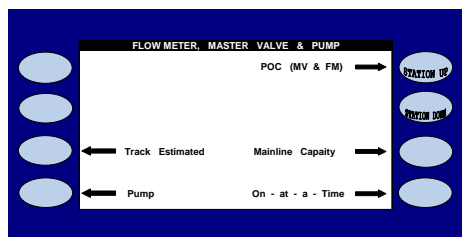


Figure 4.1

### 4A. TRACK ESTIMATED

The Track Estimated Water Use feature only appears when NO FLOW METER IN USE and none of the following are enabled:

- System Capacity
- Daily ET
- Budgets

If none of these items are in use, and you want to track estimated water usage:

1.  Press the **TRACK ESTIMATED** Menu key.

The TRACK ESTIMATED USAGE screen is displayed (Figure 4.2).

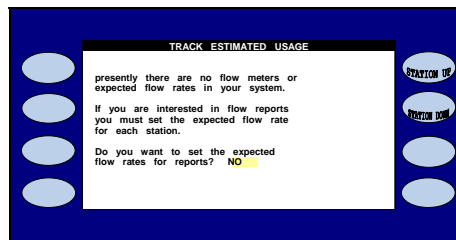


Figure 4.2



2. Press the **PLUS** or **MINUS** keys to change the **DO YOU WANT TO SET THE EXPECTED FLOW RATES FOR REPORTS?** setting.

**Note:** When the selection on the screen is changed to **YES**, additional instructions will be displayed (Figure 4.3).

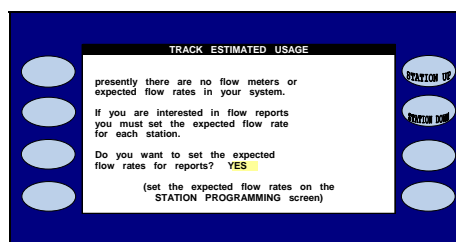


Figure 4.3

**Note:** You will have to go back to the STATION PROGRAMMING screen for each station and enter an expected flow rate for each individual station.

### THIS CONCLUDES THE TRACK ESTIMATED SECTION

### 4B. POC (MV & FM) SETUP

The POC (MV & FM) setup is used to enter the type and size of the Master Valve/Flow Meters connected to this controller. You can also enter the K & Offset values for FMBX style flow meters.

**Note:** The multiple Master Valve / Flow Meter option will only be available if the (-F) option is installed in the controller. See Section 12 (-F) Option for more information.

From the FLOW METER, MASTER VALVE & PUMP screen (Figure 4.1).

1.  Press the **POC (MV & FM)** Menu key.

The POINT OF CONNECTION (MV & FM) screen is displayed (Figure 4.4).

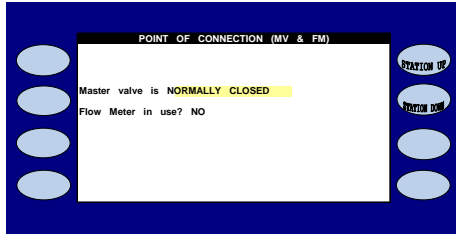




Figure 4.4

2.  Press the **PLUS** or **MINUS** keys to change the MASTER VALVE IS setting.

The Master Valve default setting is for a normally closed Master Valve. There are two (2) settings,

- **NORMALLY CLOSED:** A normally closed Master Valve is in the closed position until voltage is applied to open it.
- **NORMALLY OPEN:** A normally open Master Valve is in the open position until voltage is applied to close it.

**Note:** Be sure to select the correct type of Master Valve installed. If it is incorrect, the Master Valve will close whenever a station is irrigated and no water will flow when a valve is turned on.

3.  Press the blue **ARROW** keys to move the cursor to the FLOW METER IN USE? setting.

The POINT OF CONNECTION screen will change to display (Figure 4.5).

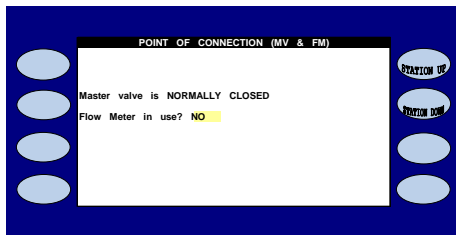



Figure 4.5

4.  Press the **PLUS** or **MINUS** keys to change the FLOW METER IN USE? setting.

The POINT OF CONNECTION screen will change to display (Figure 4.6).

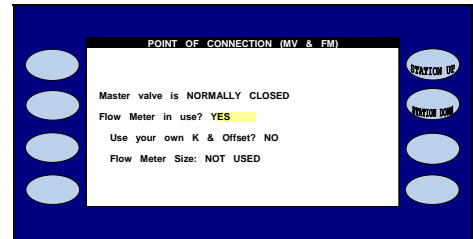


Figure 4.6

If using a Calsense FMBX flow meter, see:

1. FMBX flow meter setup

If using a regular Calsense flow meter, see:

2. Regular flow meter setup

#### 4B.1 FMBX flow meter setup

If the flow meter installed on the system is a Calsense FMBX, change the “Use your own K & Offset” to YES, (The screen will appear as shown in Figure 4.7).

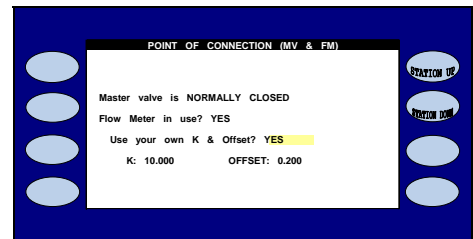






Figure 4.7

1.  Press the blue **ARROW** keys to move the cursor to the K: setting.
2.  Press the **PLUS** or **MINUS** keys to change the number.
3.  Press the blue **ARROW** keys to move the cursor to the OFFSET: setting.
4.  Press the **PLUS** or **MINUS** keys to change the number.


**Note:** The two settings that must be set are the K value and the Offset. If you know these values enter them now. If not, Call Calsense at 1-(800)-572-8608 for assistance.


The ranges for these two settings are:

- **K:** 0.200 to 800.00
- **OFFSET:** 0.000 to 1.000

**4B.2 Regular flow meter setup**

If the answer to Use your own K & Offset is NO.

- 

Press the blue **ARROW** keys to move the cursor to the FLOW METER SIZE: setting.
- 

Press the **PLUS** or **MINUS** keys to change the flow meter type.

Refer to the chart (Figure 4.8), to choose the correct flow meter type.

MODEL NUMBER	SIZE
FM-1	1" PLASTIC FLOW METER
FM-1B	1" BRASS FLOW METER
FM-1.25B	1 ¼" BRASS FLOW METER
FM-1.5	1 ½" PLASTIC FLOW METER
FM-1.5B	1 ½" BRASS FLOW METER
FM-2	2" PLASTIC FLOW METER
FM-2B	2" BRASS FLOW METER
FM-3	3" PLASTIC FLOW METER


Figure 4.8

**THIS CONCLUDES THE POC (MV & FM) SECTION**

**4C. LEARN EXPECTEDS**

The Learn Expecteds option on the controller will allow the controller to learn the expected flow rate for each station It is only available if a flow meter is in use.

From the MAIN MENU screen:

- 

Press the **FLOW** Menu key.

The FLOW METER, MASTER VALVE & PUMP screen is displayed (Figure 4.9).

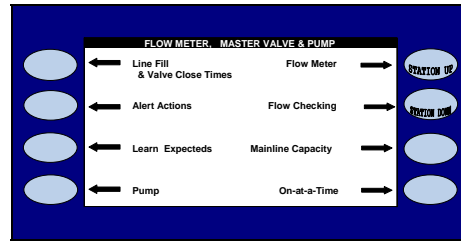



Figure 4.9

- 

Press the **LEARN EXPECTEDS** Menu key (Figure 4.9).

The LEARN THE EXPECTED FLOW RATES screen is displayed (Figure 4.10).

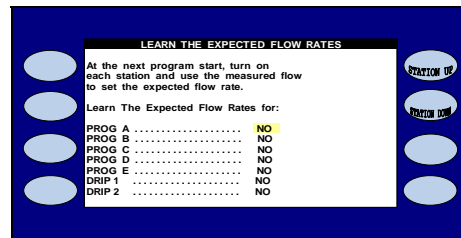




Figure 4.10

- **LEARN EXPECTEDS:** Setting a value to YES will allow the controller to learn the expected flow rate for each station at the next program start. Once the flow rate has been recorded the entry on the screen will default back to NO.

- 

Press the **PLUS** or **MINUS** keys to select the program.
- 



Press the blue **ARROW** keys to change the setting.

**THIS CONCLUDES THE LEARN EXPECTED SECTION**

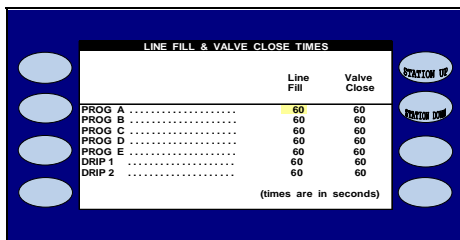
**4D. LINE FILL & VALVE CLOSE TIMES**

The Line Fill & Valve Close Times are used to set the amount of time each valve time will have to stabilize before checking flow.

After you have enabled the flow meter on the FLOW METER screen as described in Section 4A:



-  Press the **BACK** key twice to return to the FLOW METER, MASTER VALVE, & PUMP screen (Figure 4.1).
-  Press the **LINE FILL & VALVE CLOSE TIMES** Menu key.

The LINE FILL & VALVE CLOSE TIMES screen is displayed (Figure 4.11).




**Figure 4.11**

- LINE FILL TIMES:** The delay time in seconds that the controller will wait to check flow rates on a station allowing the flow to stabilize.
- VALVE CLOSE TIMES:** The delay time in seconds that the controller will wait to check flow on the very next valve allowing time for the previous valve to close.

-  Press the blue **ARROW** keys to move the cursor to the LINE FILL TIME for Program A.
-  Press the **PLUS** or **MINUS** keys to set the desired time (in seconds).

**Note:** Use this same method to change the VALVE CLOSE TIME for Program A and then repeat these steps for each program on the list.


-  Press the **BACK** key to return to the FLOW METER, MASTER VALVE, & PUMP SETUP screen (Figure 4.9).

**THIS CONCLUDES THE LINE FILL & VALVE CLOSE TIMES SECTION**

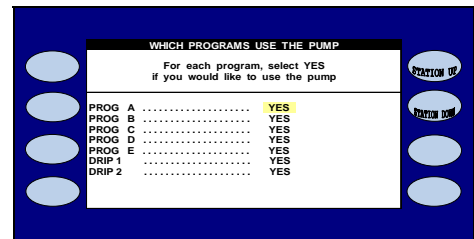
**4E. PUMP**

If you are using a pump for any one of your valves you will have to set the controller to recognize that there is a pump in use and on which program it will be used on.


From the FLOW METER, MASTER VALVE & PUMP screen (Figure 4.1).

-  Press the **PUMP** Menu key.


The WHICH PROGRAMS USE THE PUMP screen is displayed (Figure 4.12).




**Figure 4.12**

-  Press the blue **ARROW** keys to move the cursor to the program desired.

The default setting is set to YES on all programs. This means that the controller's pump output will be activated whenever a station on any program is activated.

-  Press the **PLUS** or **MINUS** keys to change any Program.

**Note:** If the Pump Output Enabled setting is set to NO on a program, the pump output will not activate when a station on that program is activated.

- 


Press the **BACK** key to return to the Flow Meter, Master Valve & Pump screen (See figure 4.1).

**THIS CONCLUDES THE PUMP SECTION**

**4F. MAINLINE CAPACITY**

System capacity is defined by the maximum flow rate that your system can operate at during irrigation and while idle.

From the FLOW METER, MASTER VALVE & PUMP screen (Figure 4.1):

- 

Press the **MAINLINE CAPACITY** Menu key.

The MAINLINE BREAK SETTINGS screen is displayed (Figure 4.13).

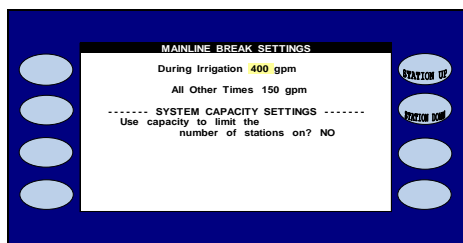




Figure 4.13

- 

Press the blue **ARROW** keys to move the cursor to the DURING IRRIGATION gpm setting.
- 

Press the **PLUS** or **MINUS** keys to change the flow rate.

Use the same method to change the ALL OTHER TIMES number.


- DURING IRRIGATION:** The during irrigation number is the mainline break number used while the controller is irrigating.
- ALL OTHER TIMES:** The all other times number is the mainline break number used when the controller is not irrigating.

The range for both of these settings are:

**1 to 4000 gpm**

- USE CAPACITY TO LIMIT THE NUMBER OF STATIONS ON?:** If you want to use capacity to limit the number of stations on change this to YES.

This will open up the portion of the screen dealing with System Capacity with or without Pump (Figure 4.14).

- 

Press the **PLUS** or **MINUS** key to change the capacity numbers.

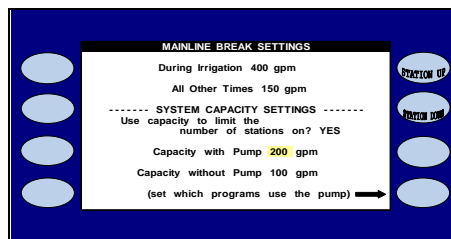


Figure 4.14


**Capacity with Pump:** When a program irrigates with a pump the gpm limit that you set will not be exceeded.

**Capacity without Pump:** When a program irrigates without a pump, the gpm limit you set will not be exceeded.

The range for both of these settings are:

**1 to 4000 gpm**

**Note:** Pump and non-pump programs will not run simultaneously on the same controller/ FLOWSENSE® chain.

- 

If you did not select SET WHICH PROGRAMS TO USE PUMP in the pump section of this manual then press the **SET WHICH PROGRAMS TO USE THE PUMP** Menu key (Figure 4.14).

See Part E of this section for instructions.

**THIS CONCLUDES THE MAINLINE CAPACITY SECTION**

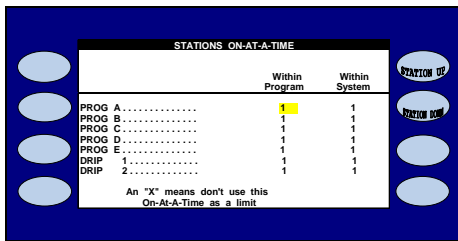
**4G. ON-AT-A-TIME**

The On-at-a-Time section of the controller is used to set up the number of valves that you want to come on simultaneously within a program, and also within a controller.


From the FLOW METER, MASTER VALVE & PUMP screen (Figure 4.1):

1.  Press the **ON-AT-A-TIME** Menu key.


The STATIONS ON-AT-A-TIME screen is displayed (Figure 4.15).



**Figure 4.15**

2.  Press the blue **ARROW** keys to move the cursor to the Program and Within Program setting desired.

**Note:** The default setting is set to 1 on all programs.

3.  To change the settings press the **PLUS** or **MINUS** keys for any number to change the setting.

- **WITHIN PROGRAM:** This section allows you to choose the amount of valves that you want to set as a limit to come on at a time within a program.
- **WITHIN CONTROLLER:** This section allows you to choose the amount of valves that you want to set as a limit to come on at a time within the controller.

The range for these two settings are:

- **1 - 4:** This choice allows the user to set the limit of stations operating simultaneously from a single up to four valves within the given program.

**Note:** This is unless you are using **FLOWSENSE®**. See Section 11 (-FL) **FLOWSENSE®** for more details.

- **X:** This choice allows the user to set the controller so that it irrigates to your system capacity, or electrical limit.

*Example:*


	<u>Within Program</u>	<u>Within Controller</u>
Program A	1	2
Program B	1	2

This example allows the user to set up one (1) valve on at a time for Programs A and B. The controller will allow both Programs to have one (1) valve each run simultaneously for a total of two (2) on within controller.

*Example:*

	<u>Within Program</u>	<u>Within Controller</u>
Program A	1	1
Program B	3	3

This example allows the user to set up one (1) valve on at a time for Programs A. The controller will only allow one valve to operate while program A is running. Program B is set up to operate 3 valves on at a time, and will only operate up to three valves when Program B is running.

4.  Press the **BACK** key to return to the FLOW METER, MASTER VALVE, & PUMP screen (See figure 4.1).

**Note:** On-At-A-Time will affect Test, Programmed, and Manual Irrigation.

**THIS CONCLUDES THE ON AT A TIME SECTION**

**4H. FLOW CHECKING**

Flow checking allows you to have the controller compare the flow of each station during irrigation to the learned expected flow and alert you of any problems.

From the FLOW METER, MASTER VALVE & PUMP SETUP screen (Figure 4.1).

1. Press the **FLOW CHECKING** Menu key

The FLOW CHECKING screen is displayed (Figure 4.16).

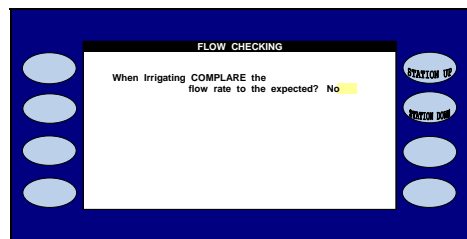


Figure 4.16

This will open up the ALLOWABLE portion of the screen when you select YES to the WHEN IRRIGATING COMPARE THE FLOW TO THE EXPECTED ? question (Figure 4.17).

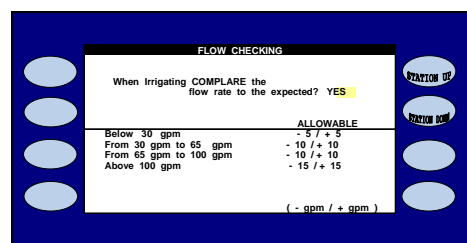


Figure 4.17

2. Press the blue **ARROW** keys to change the Allowable settings. The default settings are:

**BELOW:**                -5 / +5  
**FROM / TO:**        -10 / +10  
**FROM / TO:**        -10 / +10  
**ABOVE:**             -15 / +15

**Note:** The above settings are defaulted in the controller and can be changed by the user.

3. To change the settings press the **PLUS** or **MINUS** keys for any number to change the setting.

**Below:** This section allows you to enter the fluctuation range for the low end of your normal operating flow. Use the (-) and (+) entries to set the range.

*Example:*

If you set the below limit at 30 gallons per minute.  
 and set your limit at -5/+5,  
 You will be alerted if the flow at the low end of the scale fluctuates by more than 5 gallons per minute in either direction.  
 That is less than 25 gpm or more than 35 gpm

**1<sup>st</sup> From / To:** This section allows you to set the fluctuation limits for the lower range of your medium flowing valves. In this box you want to enter the normal operating range of water flow. Then in the (-) and (+) blocks enter the range of fluctuation that you deem normal.

*Example:*

If you set the below limit at 30 gpm to 65 gpm.  
 and set your limit at -10/+10,  
 You will be alerted if the flow at the low end of the scale fluctuates by more than 10 gallons per minute in either direction.  
 That is less than 20 gpm or more than 75 gpm

**2<sup>nd</sup> From / To:** This section allows you to set the fluctuation limits for the high end of your medium flowing valves. In this box you want to enter the normal operating range of water flow. Then in the (-) and (+) blocks enter the range of fluctuation that you deem normal.



*Example:*

If you set the below limit at 65 gpm to 100 gpm.

and set your limit at -10/+10,

You will be alerted if the flow at the low end of the scale fluctuates by more than 10 gallons per minute in either direction.

That is less than 55 gpm or more than 75 gpm

**Above:** This section allows you to enter the fluctuation range for the high end of your normal operating flow. Use the (-) and (+) entries to set the range.

**Note:** You will want to set this allowable range up a little wider due to the amount of water flow.

*Example:*

If you set the above limit at 100 gallons per minute.

And set your limit at -15/+15.

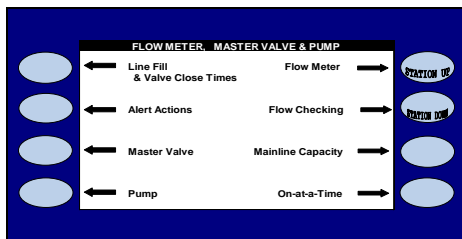
You will be alerted if the flow at the high end of the scale fluctuates by more than 15 gallons per minute in either direction.

That is less than 85 gpm or more than 115 gpm



4. Press the **BACK** key to return to the FLOW METER, MASTER VALVE, & PUMP screen (Figure 4.1).

**Note:** This will enable the Alert Actions option to the FLOW METER, MV & PUMP screen See figure 4.18).



**Figure 4.18**

**THIS CONCLUDES THE FLOW CHECKING SECTION**



**4I. ALERT ACTIONS**

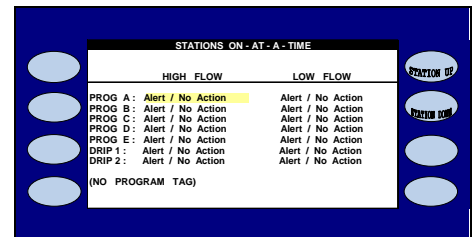
The Alert Actions section of the controller allows you to setup the way in which you want the controller to inform you of any problems. The Alert Actions setting defaults with Alert / No Action set for all programs. There are three possible settings:

- **Alert / No Action:** An alert is displayed on the screen but the valve continues to irrigate.
- **Alert / Shut-Off:** An alert is displayed on the screen and the value is shut off.
- **No Alerts:** No alert is displayed and the valve continues to irrigate.




From the FLOW METER, MASTER VALVE & PUMP screen (Figure 4.1).

1.  Press the **ALERT ACTIONS** Menu key.

The ALERT ACTIONS screen is displayed (Figure 4.19).



**Figure 4.19**

2.  Press the blue **ARROW** keys to move the cursor to the Program HIGH FLOW and LOW FLOW settings.
3.  Press the **PLUS** or **MINUS** keys to change the settings.
4.  Press the **MAIN MENU** key to return to the MAIN MENU screen.

**THIS CONCLUDES THE ALERTS / ACTIONS SECTION**



## SECTION 5: WEATHER

The Weather section of the controller is used to set up the ET Gage, Rain Bucket, Wind Gage, Rain Switch, Budgets, and Moisture Sensors.

### 5A. ET GAGE

The ET Gage setting in the controller is used for:

- Setting ET irrigation day
- Selecting ET gage Usage\*
- Logging ET Gage Pulses\*
- Setting Gage fill percentage\*
- Manually entering pulses\*\*
- Skipping tonight's entries\*\*

\* Only if (-G) option installed in controller.

\*\* Used for troubleshooting, or servicing ET Gage.

#### 5A.1. ET Gage setup

From the MAIN MENU screen (Figure 5.1):

1.  Press the **WEATHER** Menu key.

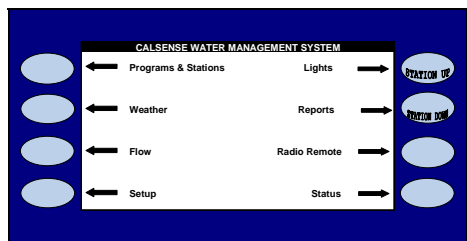


Figure 5.1

The WEATHER SETUP screen is displayed (Figure 5.2).

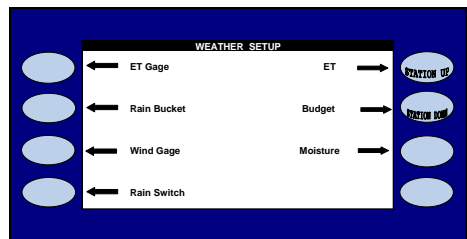


Figure 5.2

2.  Press the **ET GAGE** Menu key. The ET GAGE screen is displayed (Figure 5.3).

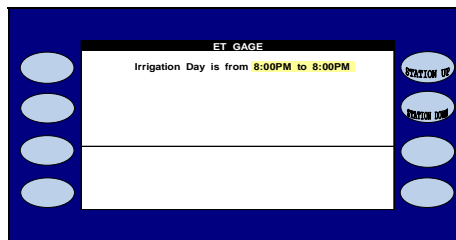




Figure 5.3

- **Irrigation Day is from 8:00PM to 8:00PM:** This setting is for the time period that you want your ET information to be collected for each day. Keep in mind that you want this time to be before your first irrigation Start Time for that day so that you are using the most current ET information.

3.  Press the **PLUS** or **MINUS** keys to change the setting.

**Note:** Following steps are for (-G) option only. If no ET Gage is in use skip this section.

4.  Press the blue **ARROW** keys to move the cursor to the IS THERE AN ET GAGE? (Figure 5.4).

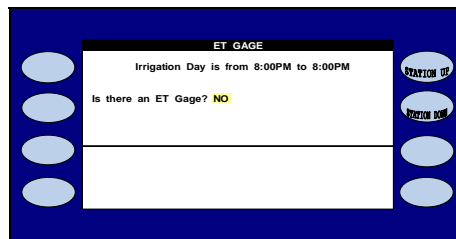



Figure 5.4

5.  Press the **PLUS** or **MINUS** keys to change the setting.

If YES is selected the screen will change to read: (Figure 5.5).

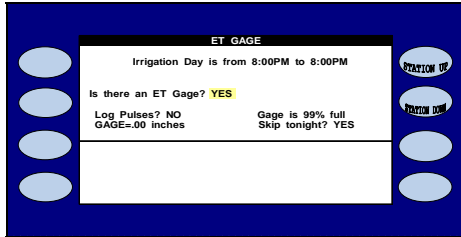



Figure 5.5

6.  Press the blue **ARROW** keys to move the cursor to the LOG PULSES? entry (Figure 5.6).

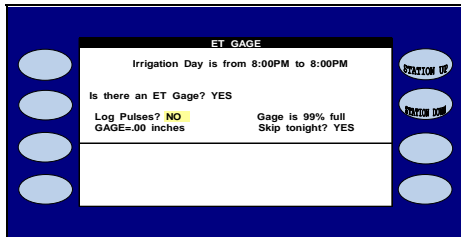




Figure 5.6

- **Log Each Pulse?:** The default is set to NO. Changing to the YES setting gives you the option of keeping a record of each ET Gage pulse sent to the controller. This information is located in the Alerts. This is helpful when first setting up the ET Gage to make sure that it is working properly, but can be set to NO after you have verified the ET Gage is working properly.

7.  Press the **PLUS** or **MINUS** keys to change the setting.
8.  Press the blue **ARROW** keys to move the cursor to the GAGE IS 99% FULL setting (Figure 5.7).

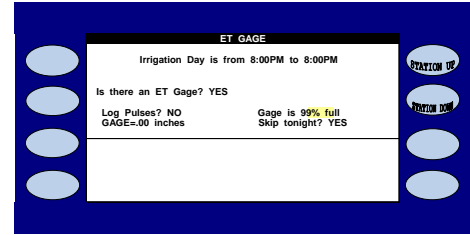




Figure 5.7

- **Gage is 99% full:** The percent full counter is used to reset the counter after the ET Gage has been refilled during periodic maintenance.

9.  Press the **PLUS** or **MINUS** keys to change the setting.
10.  Press the blue **ARROW** keys to move the cursor to the GAGE=.00 INCHES setting (Figure 5.8).

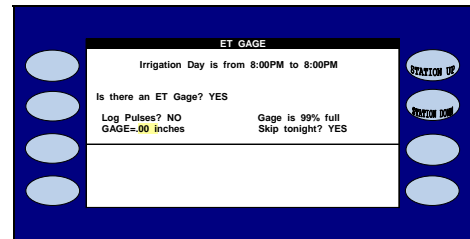



Figure 5.8

- **GAGE=.00 inches:** This option allows you to edit the amount of inches of Measured ET. Some of the reasons for editing this number:
  - Servicing the ET gage and removing erroneous logged pulses.
  - Gage temporarily not working and a need to log pulses for that day.
  - Editing number up or down due to specific circumstances.

**Note:** Daily pulses show at this location.

11.  Press the **PLUS** or **MINUS** keys to change the setting.



12. Press the blue **ARROW** keys to move the cursor to the **SKIP TONIGHT?** (Figure 5.9).

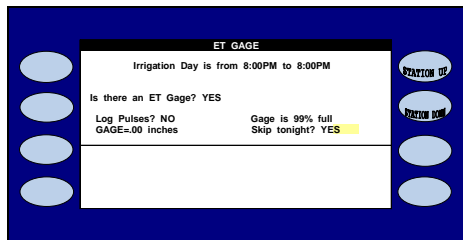


Figure 5.9

- **SKIP TONIGHT?:** Selecting YES causes the GAGE=inches number to be left out of the ET table for this twenty four hour period. A historical value will be used instead.

**Note:** The Skip Tonight option is used for troubleshooting the ET gage. Pulses created during troubleshooting will not be entered into the ET Table if YES is selected.



13. Press the **BACK** key to return to the WEATHER SETUP screen (Figure 5.2).

**THIS CONCLUDES THE ET GAGE SECTION**

**5B. RAIN BUCKET**

The Rain Bucket setting in the controller is used for recording the amount and rate of rainfall, and calculating station run times accordingly by use of the following:

- Setting irrigation rain stop value
- Set Maximum rain in one hour value
- Set Maximum rain in 24 hour value
- Set rain build up value
- Set use of rain by program

Skip Rain Bucket setup if controller has no (-RB) option and you **are not** sharing rain to controller.

If the controller in use has a **(-RB)** option installed and a Rain Bucket connected see:

1. Rain setup with Rain Bucket installed.

If the controller in use **does not** have the **(-RB)** option installed see:

2. Rain setup (without Rain Bucket installed) and you are sharing rain to controller.

**5B.1 Rain setup with Rain Bucket installed**

From the WEATHER SETUP screen (Figure 5.2).

1. Press the **RAIN BUCKET** Menu key.

The RAIN BUCKET SETUP screen is displayed (Figure 5.10).

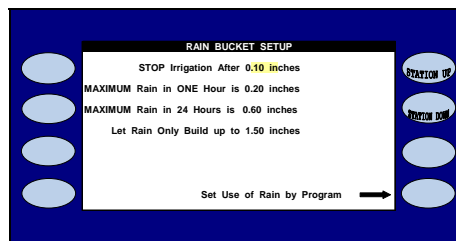


Figure 5.10


The four (4) settings on the screen determine how much actual rainfall will be placed into the rain table, which is used to offset irrigation run times. The following is a description of each:


**Note:** Each value in the following definitions denoted in **red** is a default setting and can be adjusted by the user.

- **Stop irrigation after:** This setting determines how much rain must fall, before the controller will start accumulating rainfall values in the rain table. It also determines when to halt any on going irrigation. In figure 5.10, **(0.10)** inches of rain will have to fall before any rain data starts to accumulate in the rain table, or irrigation is stopped.
- **Maximum Hourly Rain:** This setting determines the maximum amount of rain that will be put in the rain table after a period of one (1) hour of rain. In figure 5.10, a maximum of **(0.20)** inches of rain will be put into the rain table, no matter how much rain falls in a one (1) hour period. The

amount of rain from this setting put into the rain table, will increase only until it reaches the 24 HOUR TOTAL setting.


- **Maximum 24 Hour Total:** This setting determines the maximum amount of rain that will be put into the rain table in a 24 hour period. In figure 5.10, a maximum of **(0.60)** inches of rain will be put into the table, no matter how much rain falls in a 24 hour period. The amount of rain from this setting put into the rain table, will increase only until it reaches the LET RAIN ONLY BUILD UP TO :setting.
- **Let Rain Only Build Up to:** This setting determines the maximum amount of rain that will be stored in the rain table. In figure 5.10, the controller will stop storing rain data in the rain table if the Maximum 24 Hour Total reaches **1.50** inches of rain.

2.  Press the **PLUS** or **MINUS** keys to change the settings.

3.  Press the blue **ARROW** key to move the cursor to the next entry.

- **Set Use of Rain by Program:** This section describes how to enable the use of rain in the ET2000e controller. Each program can be set individually to either use or not use rain to offset irrigation run times.

From the RAIN BUCKET SETUP screen (Figure 5.10):

4.  Press the **SET USE OF RAIN BY PROGRAM** Menu key.

The USE OF RAIN BY PROGRAM screen is displayed (Figure 5.11).

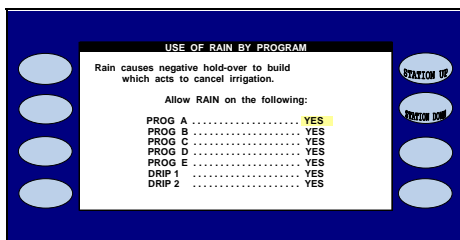





Figure 5.11

You have the option of enabling or disabling the use of rain (negative hold over) for any of the controller's seven programs. If you select YES, rain (negative hold over) will be used for that program to reduce irrigation run times. If you select NO, rain will have no effect on irrigation run times for that program. If there is no rain bucket installed and you are not sharing rain data through the Calsense **Command CENTER** program, these settings will have no effect on irrigation.

**Note:** Negative Hold-over is time subtracted from station run times. This is caused when user set rain parameters are crossed.

5.  Press the **PLUS** or **MINUS** keys to change the setting.

6.  Press the blue **ARROW** keys to move the cursor to the next entry.

7.  Press the **MAIN MENU** key to return to the MAIN MENU screen (Figure 5.1).

**THIS CONCLUDES RAIN SETUP WITH RAIN BUCKET INSTALLED**

**5B.2 Rain setup ( without Rain Bucket installed ) and you are sharing rain to controller.**

From the WEATHER SETUP screen (Figure 5.2):

1.  Press the **RAIN BUCKET** Menu key.

The RAIN BUCKET SETUP screen is displayed (Figure 5.12).

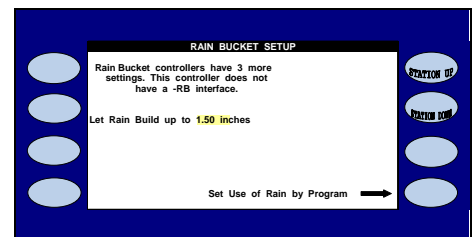



Figure 5.12

If a controller is not wired to a rain bucket, the RAIN BUCKET SETUP screen will only have one setting (Figure 5.12). This setting is described below:


- **Let Rain Only Build Up to:** This setting determines the maximum amount of rain that can be stored in the rain table. In figure 5.12 the controller will stop storing rain data in the rain table if the Maximum 24 Hour Total reaches **1.50** inches of rain.

If you are not sharing rain data using the Calsense **Command CENTER** software, this setting will have no effect on irrigation.

2.  Use the **PLUS** or **MINUS** key to change the setting.

- **Set Use of Rain by Program:** This section describes how to enable the use of rain in the ET2000 controller. Each program can be set individually to either use or not use rain to offset irrigation run times.

From the RAIN BUCKET SETUP screen (Figure 5.12).

3.  Press the **SET USE OF RAIN BY PROGRAM** Menu key.

The USE OF RAIN BY PROGRAM screen is displayed (Figure 5.13).

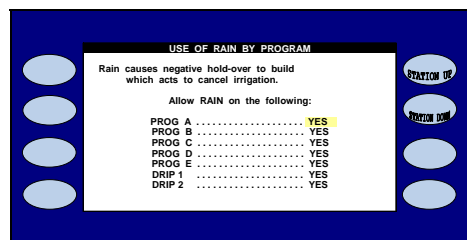





Figure 5.13

Here you will have the option of enabling or disabling the use of negative hold-over (rain) for any of the controller's seven programs. If you select YES, rain (negative hold over) will be used for that program to reduce irrigation run times. If you select NO, rain will have no effect on irrigation run times for that program.

If there is no rain bucket installed and you are not sharing rain data through the Calsense **Command CENTER** program, these settings will have no effect on irrigation.

4.  Press the **PLUS** or **MINUS** keys to change the setting.
5.  Press the blue **ARROW** keys to move the cursor to the next entry.
6.  Press the **MAIN MENU** key to return to the MAIN MENU screen (Figure 5.1).

**THIS CONCLUDES RAIN SETUP WITHOUT RAIN BUCKET INSTALLED SECTION**

 **5C. WIND GAGE**

The Wind Gage setting in the controller is used to determine at what speed irrigation will be paused / resumed by use of the following:

- Selecting Wind Gage activation. (**-WG**)
- Setting wind pause speed.
- Setting wind resume speed.
- Selecting use of Wind by Program.

**5C.1 Wind Gage setup**

From the WEATHER SETUP screen (Figure 5.2):

1.  Press the **WIND GAGE** Menu key.

The WIND GAGE SETUP screen is displayed (Figure 5.14).

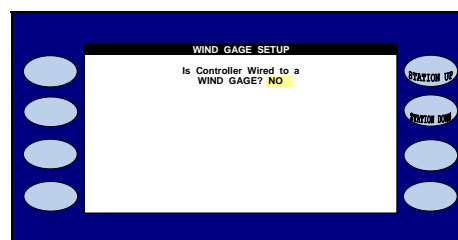



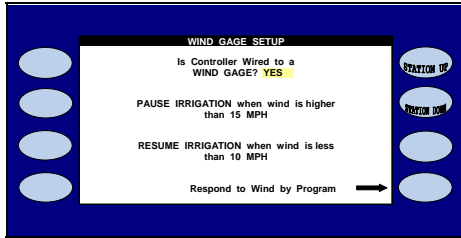
Figure 5.14

The default setting is NO. If you are currently using a wind gage on this controller then change the setting to YES.

- 


Press the **PLUS** or **MINUS** keys to change the settings.

The WIND GAGE SETUP screen will change to reveal the irrigation wind settings (Figure 5.15).

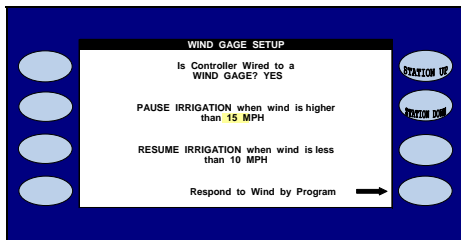


**Figure 5.15**

**Note:** The pause and resume irrigation default settings are 15 MPH to pause and 10 MPH to resume.


- 


Press the blue **ARROW** keys to move the cursor to the next entry (Figure 5.16).



**Figure 5.16**

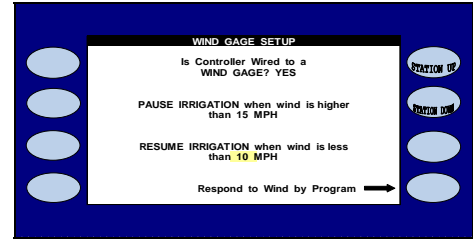
To change the wind speed that you want the irrigation to pause at:

- 


Press the **PLUS** or **MINUS** keys (Figure 5.17).
- 

Press the blue **ARROW** keys to move the cursor to the next entry.

To set the Miles Per Hour that you want the controller to resume irrigation at, (Figure 5.17).



**Figure 5.17**

- 

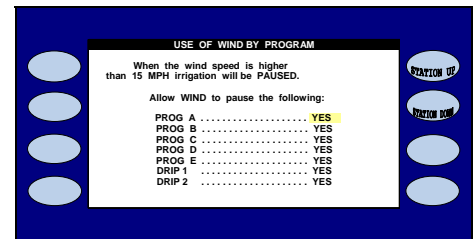
Use the **PLUS** or **MINUS** keys to change the speed (Figure 5.17).

**5C.2 Respond to Wind by Program**

- 


Press the **RESPONDED TO WIND BY PROGRAM** Menu key.


The USE OF WIND BY PROGRAM screen is displayed (Figure 5.18).




**Figure 5.18**

You can select the programs that you want to be affected by wind. The default setting is YES. If you **do not** want programs to be affected by wind change the setting to NO for the appropriate program.

- 

Press the **PLUS** or **MINUS** keys to change the settings.
- 

Press the blue **ARROW** key to move the cursor to the next entry.
- 

Press the **MAIN MENU** key to return to the MAIN MENU screen (Figure 5.1).


**THIS CONCLUDES THE WIND GAGE SETUP SECTION**

**5D. RAIN SWITCH**

This section of the controller is used to activate the use of a rain switch and have the controller turn irrigation off due to rain detection.

**5D.1 Rain Switch setup**

From the WEATHER SETUP screen (Figure 5.2).

1.  Press the **RAIN SWITCH** Menu key if you want to activate a Rain Switch.

The RAIN SWITCH SETUP screen is displayed (Figure 5.19).

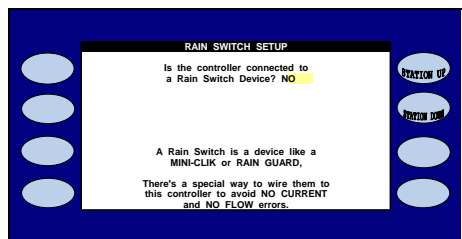



Figure 5.19

2.  Press the **PLUS** or **MINUS** keys to change the setting.

If you select YES, the screen will change to read (Figure 5.20), "Irrigation will be stopped when the rain switch detects rain". If you do not want irrigation to be affected by the rain switch leave the setting at the default setting of NO (Figure 5.20).

**CAUTION:**

If YES is selected, and the controller is **not** hooked up to a rain switch **irrigation will be halted**. This is due to rain switch wiring requirements.

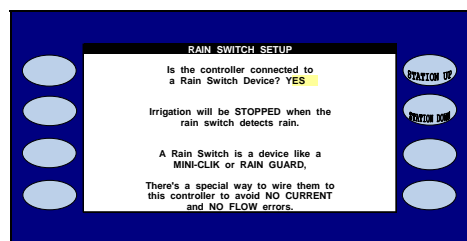


Figure 5.20


**THIS CONCLUDES THE RAIN SWITCH SECTION**

**5E. ET**

The ET section of the controller is used to program the use evapotranspiration data accessed from an ET Gage, or pre-determined values to compute irrigation run times using the following:

- Irrigate using ET table
- Using ET averaging
- Adjust allowable percentage of historical ET
- Use of Crop Coefficients

From the WEATHER SETUP screen (Figure 5.2):

1.  Press the **ET** Menu key.

The DAILY ET SETUP screen is displayed (Figure 5.21).

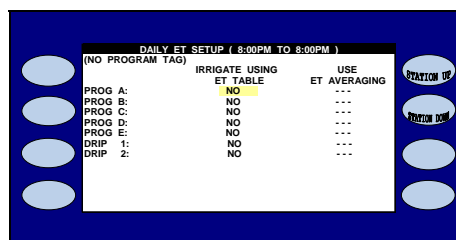



Figure 5.21

**Note:** The text line directly under the heading bar will have each program tag if you are currently using them. (See Section 3 Start Times & Water Days / Name:). If you do not have any selected the default (.....) will appear.

**5E.1 Irrigate using ET table**


A NO next to a program indicates the program is not using ET. Once YES is selected for a program, any station assigned to that program will use daily ET to automatically adjust the amount of time the station will run during its next irrigation.

1.  Press the **PLUS** or **MINUS** keys to change the setting.

**Note:** If the setting is changed to YES for a program, the USE ET AVERAGING setting will automatically change to YES for that particular program.





- 
 Press the **PLUS** or **MINUS** keys to change the setting.

**5E.2 Use ET averaging**

A YES next to a program indicates ET averaging is enabled for that program, which is only available if the program is in daily ET mode. With ET averaging ON the controller will not use a single ET valve to calculate the next run times. Instead it will use the average of the last 7 days of ET (Figure 5.22).

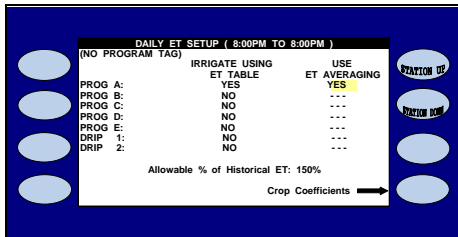


Figure 5.22

**5E.3 Allowable % of Historical ET**

This setting controls the maximum allowable amount of ET that can be used to calculate station run times. The default is 150%, which means that if real-time ET measured by the gage, exceeds 150% of historical ET, the controller will place an ET value in the ET table equal to 150% of historical ET instead of the actual real-time ET. This setting allows the user to control the maximum amount of total irrigation time for sites that have a limited water window (Figure 5.23).

**Note:** The water window is the time from when you can start irrigating to when you have to end irrigation.

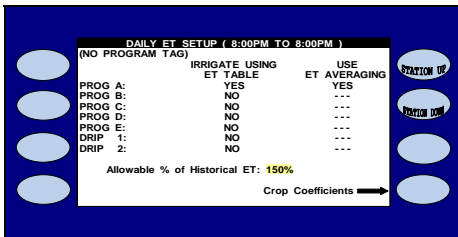




Figure 5.23

**5E.4 Crop Coefficients**

This setting is used to adjust ET for a specific type of crop at different periods throughout the year. If you do not want ET to be modified, leave the selection set at NO (Figure 5.24)

From the WEATHER SETUP screen (Figure 5.2).

- 
 Press the **CROP COEFFICIENTS** Menu key.
- 
 Press the **PLUS** or **MINUS** keys to change the setting.

The CROP COEFFICIENTS screen is displayed (Figure 5.240).

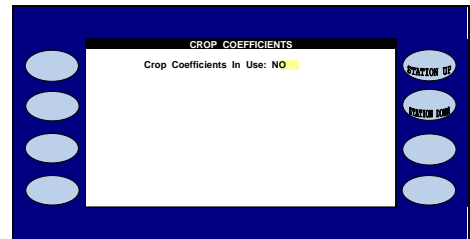


Figure 5.24

- Crop Coefficients In Use:** The default setting is set to NO. By changing it to YES the screen will show the Month and Program Columns (Figure 5.25).

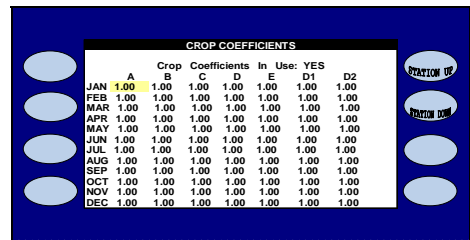




Figure 5.25

This will allow you to enter Crop Coefficient values for each month of the year, on each program in the controller. You must be familiar with crop coefficients to use this feature.

- 
 Press the **PLUS** or **MINUS** keys to change the setting.
- 
 Press the blue **ARROW** keys to move the cursor.

5.



Press the **MAIN MENU** key to return to the MAIN MENU screen (Figure 5.1).

### THIS CONCLUDES THE CROP COEFFICIENTS SECTION

#### **CAUTION:**

When using Daily ET mode you will have to set each station's flow rate, precipitation rate, and square footage area for every program using Daily ET. The following instructions cover how to set up station flow rates whether or not you have a flow meter installed.

#### **NO FLOW METER INSTALLED**

##### **5E.5 Station flow rates without a flow meter present:**

There are two methods to determine station flow rates if a Calsense flow meter is not installed on the system. The following describes each method

- **How to Calculate Station Flow rates Using Manufacturer's Published data:**

With the first method, you use a manufacturer's catalog which has the flow rates (gpm) listed for the type heads, and nozzle sizes on the system you are calculating. Simply total the flow rates for all of the nozzles on the station.

#### Example:

A station has 8 half-circle pop-ups with a flow rate of 2 gpm each, 3 full circle pop-ups at 4 gpm each and 4 quarter circle pop-up heads at 1 gpm each. The station's flow rate would be calculated as follows.

$$\begin{aligned} 8 \text{ heads} \times 2 \text{ gpm} &= 16 \text{ gpm} \\ 3 \text{ heads} \times 4 \text{ gpm} &= 12 \text{ gpm} \\ 2 \text{ heads} \times 1 \text{ gpm} &= 2 \text{ gpm} \end{aligned}$$

$$\text{Total flow} = 30 \text{ gpm}$$

- **How to calculate Station Flow rates by Measuring Station Flow Rates:**

The second method may provide more accurate results, by using the irrigation system's water meter to calculate flow rates. Use the following procedure:

- Determine the units used by the water meter (gallons, cubic feet, etc.) Make sure no other water will be flowing while you are measuring flow rates. Also, if there is more than one water meter connected to the mainline, all of them must be turned off except the one you are using to measure flow with.
- Before beginning, turn on each station to make sure there are no broken heads or pipes which may cause incorrect flow readings.
- Begin by turning on a station long enough to purge all of the air out of the system. Then simultaneously, make note of the meter reading and start timing using a stopwatch. After 3 minutes have elapsed, make note of the water reading again. Subtract the starting meter reading from the ending meter reading. This will give you the amount of water used by the valve in 3 minutes. Continue this procedure until all stations have been measured.
- To calculate the flow rate, divide the amount of water the station used (measured in gallons) by 3 minutes, this will give you the station's flow rate measured in gpm's.

#### Example #1

(if water meter units are in gallons):

The starting meter reading is 312,121 gallons. After 3 minutes the ending meter reading is 312,378 gallons. The flow rate is calculated as follows:

$$\begin{aligned} 312,378 \text{ gallons} - 312,121 \text{ gallons} &= 257 \text{ gallons} \\ 257 \text{ gallons} \div 3 \text{ minutes} &= 85.6 \text{ GPM} \end{aligned}$$



Example #2

(If water meter units are in cubic feet or CF):

The starting meter reading is 9,975 CF. After 3 minutes, the ending meter reading is 10,003 CF. The flow rate is calculated as follows:

$$10,003 \text{ CF} - 9,975 \text{ CF} = 28 \text{ CF}$$

$$28 \text{ CF} \times 7.48 \text{ gallons} = 209.4 \text{ gallons}$$

$$(1 \text{ CF} = 7.48 \text{ gallons})$$

$$209.4 \text{ gallons} \div 3 \text{ minutes} = 69.8 \text{ gpm}$$

Example #3

(if water meter units are in hundreds of cubic feet or HCF):

The starting meter reading is 12,321 HCF. After 3 minutes, the ending meter reading is 12,321.25 HCF. The flow rate is calculated as follows:

$$12,321.25 \text{ HCF} - 12,321.00 \text{ HCF} = 0.25 \text{ HCF}$$

$$0.25 \text{ HCF} \times 748 \text{ gallons} = 187 \text{ gallons}$$




$$(1 \text{ HCF} = 748 \text{ gallons})$$

$$187 \text{ gallons} \div 3 \text{ minutes} = 62.3 \text{ gpm}$$

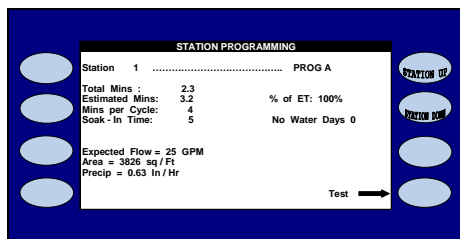
**FLOW METER INSTALLED**

**5E.6 Station Flow Rates & Area with flow meter installed.**

From the MAIN MENU screen:

1.  Press the **PROGRAMS & STATIONS** Menu key.
2.  Press the **STATIONS** Menu key.
3.  Press the **STATION UP** or **STATION DOWN** keys to select the station desired.

The STATION PROGRAMMING screen is displayed (Figure 5.26).



**Figure 5.26**

**Last Min:** This is the amount of time last irrigated on this station prior to selecting the use of Daily ET.




**Estimated Mins:** This is the total estimated minutes for this station using Daily ET, (calculated automatically).

**% of ET:** This value can be adjusted to increase or decrease the amount of estimated time on a station based on percentage of ET.

**Expected Flow:** This is the station expected flow rate. You can either learn the expected flow rate (See Section 4 Learn Expecteds), or set the flow rate number yourself.

**Area:** This is the amount of area in square feet that the heads assigned to this station encompass.

**Precip:** This entry is the precipitation rate for all of the heads assigned to this valve / station and is calculated automatically by using the flow rate and area square footage.

4.  Press the blue **ARROW** keys to move the cursor to the setting.
5.  Press the **PLUS** or **MINUS** keys to change the highlighted selection.
6.  Press the **MAIN MENU** key to return to the MAIN MENU screen (Figure 5.1).

**THIS CONCLUDES THE ET SECTION**

**5F. BUDGET**

The Budget feature of the controller allows you to compare actual water usage with a water budget that has been programmed into the controller by the user. The user will be alerted whenever the water usage exceeds the budget. Once the budget feature has been enabled, there will be three budget options to choose from:

- Directly enter the monthly budgets.
- Automatically calculate the budget amount using the total square footage and your City ET. (see Section 5H. ET State / County / City).
- Enter a yearly budget and have the controller divide it among the months using

your City ET. (see Section 5H. ET State / County / City)

From the WEATHER SETUP screen (Figure 5.2).

1. Press the **BUDGET** Menu key.

The WATER USE BUDGET screen is displayed (Figure 5.27):

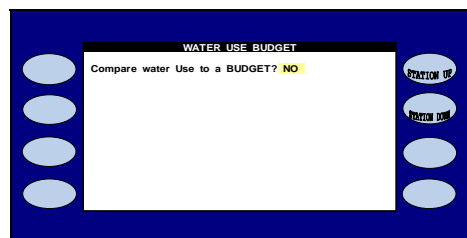


Figure 5.27

2. Press the **PLUS** or **MINUS** keys to select YES for budget use.

You will be able to choose between three different types of budget settings.

**5F.1 Directly enter the monthly budgets**

The first setting will be DIRECTLY ENTER THE MONTHLY BUDGETS (Figure 5.28).

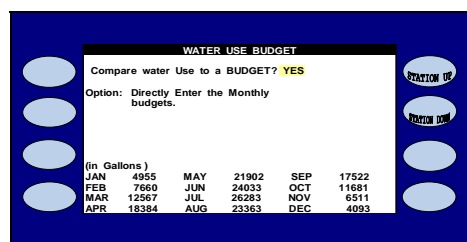


Figure 5.28

1. Press the blue **ARROW** keys to select each individual months amount.
2. Press the **PLUS** or **MINUS** keys to change each entry.

**Note:** Your entries will be saved when you leave this screen.

**5F.2 Controller will automatically calculate the budget amount using the total square footage and your city ET.**

1. In the WATER USE BUDGET screen (Figure 5.28). In the OPTIONS: setting press the **PLUS** or **MINUS** keys to change the setting to CONTROLLER WILL AUTOMATICALLY CALCULATE THE BUDGET AMOUNT USING THE TOTAL SQUARE FOOTAGE AND YOUR CITY ET (Figure 5.29).

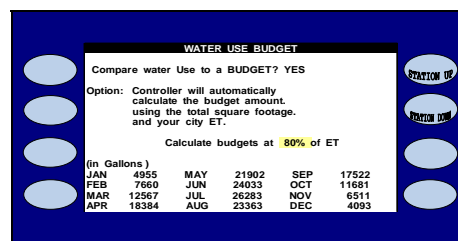


Figure 5.29

2. Press the blue **ARROW** keys to select the CALCULATE BUDGETS AT ## % OF ET setting.
3. Press the **PLUS** or **MINUS** keys to change the percentage entry. The numbers for each months entries will automatically adjust.

**Note:** Your entries will be saved when you leave this screen.

**5F.3 Enter a Yearly Budget and have the controller divide it among the months using your city ET.**

1. In the WATER USE BUDGET screen (Figure 5.28). In the OPTIONS: setting press the **PLUS** or **MINUS** keys to change the setting to ENTER A YEARLY BUDGET AND HAVE THE CONTROLLER DIVIDE IT AMONG THE MONTHS USING YOUR CITY ET setting (Figure 5.30).

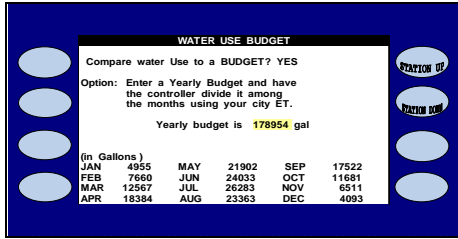




Figure 5.30

- 

Press the blue **ARROW** keys to select the YEARLY BUDGET IS ##### GAL setting.
- 

Press the **PLUS** or **MINUS** keys to change the amount entry, the numbers for each months entries will automatically adjust.

**Note:** Your entries will be saved when you leave this screen.

**THIS CONCLUDES THE BUDGET SECTION**

**5G. MOISTURE**

The Moisture section of the controller, along with the use of Calsense moisture sensors, allows you to:

- Set up moisture sensing use by program.
- Assign individual sensors to stations.
- Designate and share sensor data from master stations to slave stations.

From the WEATHER SETUP screen (Figure 5.2):

- 

Press the **MOISTURE** Menu key.

The MOISTURE SENSING SETUP screen is displayed (Figure 5.31).

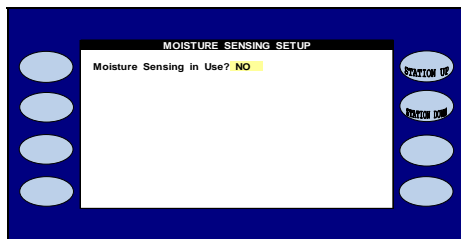



Figure 5.31

If you are currently using Moisture sensors on this controller then change the setting to YES.

- 

Press the **PLUS** or **MINUS** keys to change the settings.

**5G.1 Moisture Sensor Setup**

The MOISTURE SENSOR SETUP screen will change to reveal the Use by Program settings (Figure 5.32).

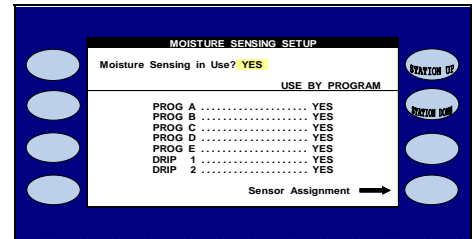



Figure 5.32

- 

Press the blue **ARROW** keys to move the cursor to the next entry (Figure 5.33)

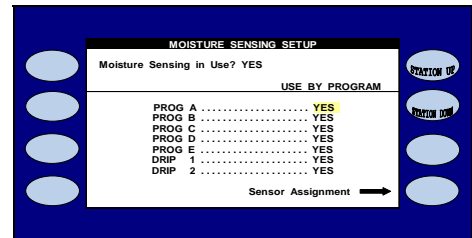




Figure 5.33

- 


Press the **PLUS** or **MINUS** keys to change the Use by Program.
- 

Press the blue **ARROW** keys to move the cursor to the next entry.

**Note:** This will allow you to set up the programs that you want to use Moisture Sensors on.

**Note:** The controller may be set up for some programs to use ET, other programs to use moisture, or programs can be set up to use a combination of the two.

**5G.2. Moisture Sensor Assignment**

1.  Press the **SENSOR ASSIGNMENT** Menu key.

The MOISTURE SENSOR ASSIGNMENT SCREEN is displayed (Figure 5.34).

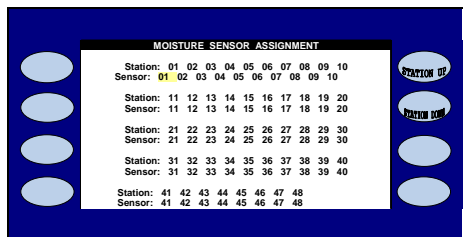


Figure 5.34

Here, you will enter which station sensors are assigned to which moisture sensor.

When using moisture sensing a representative station for each different climatic and plant material zone on the controller is given a sensor and is known as a Master station. Slave stations are stations without sensors that are assigned to a master station which share similar water requirements. The choice of groups of stations controlled by the same sensor is done at the controller within the MOISTURE SENSOR ASSIGNMENT screen.


*Example:*



Station: 01 02 03 04 05 06 07 08 09 10  
 Sensor: 01 02 03 04 05 06 07 08 09 10

becomes

Station: 01 02 03 04 05 06 07 08 09 10  
 Sensor: 01 02 **03** 04 **03 03** 07 **03** 09 10

**Note:** In the example above station 03 is the Master station (the station with the moisture sensor) and stations 05, 06, and 08 are now slave stations to station 03 (Highlighted in the example).

2.  Press the **PLUS** or **MINUS** keys to change the entry.

3.  Press the blue **ARROW** keys to move the cursor to the next entry.
4.  Once all of the Moisture Sensors have been set up properly, press the **MAIN MENU** key to return to the MAIN MENU screen (Figure 5.1).

**Note:** New settings will be available in the STATION PROGRAMMING screen for each station that is using Moisture sensing and will have to be programmed individually.

From the MAIN MENU screen:

5.  Press the **PROGRAMS & STATIONS** Menu key (Figure 5.1).

The PROGRAMS & STATIONS screen is displayed (Figure 5.35).

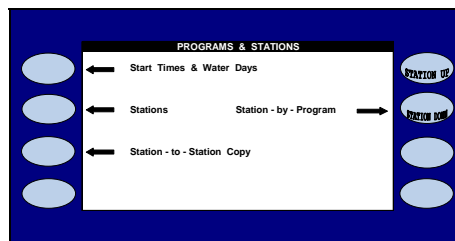


Figure 5.35

6.  Press the **STATIONS** Menu key.

The STATION PROGRAMMING screen is displayed (Figure 5.36).

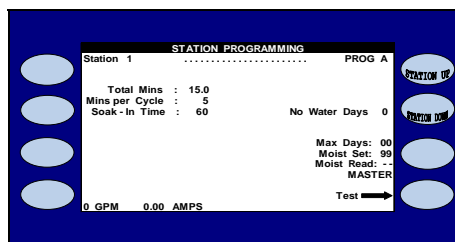



Figure 5.36

7.  Press the blue **ARROW** keys to move the cursor to the MAX DAYS entry.

- **MAX DAYS:** This entry is used to automatically bypass the moisture sensors of individual stations so they will receive their maximum programmed water time. The controller will display the number of days remaining and can be cleared at any time. After the programmed Maximum Water has elapsed, the system will automatically return to moisture sensing operation (Figure 5.37).

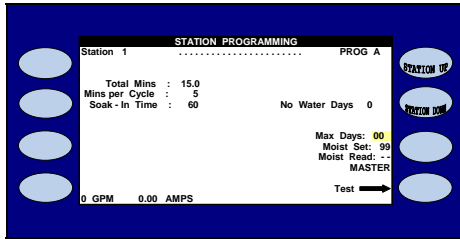




Figure 5.37

8.  Press the **PLUS** or **MINUS** keys to change the entry.
9.  Press the blue **ARROW** keys to move the cursor to the **MOIST SET** entry.

- **MOIST SET:** The Calsense Moisture Sensor has it's own numerical system of moisture readings. Typically it reads between the range of 45 (dry) to 85 (wet). By keeping moisture set points at 99, the sensors are never allowed to read above the set point value, and the controller waters the full programmed time. This occurs for the Master station as well as all slave stations assigned to the Master Station. After a few weeks, the slave areas should be checked and readjusted if necessary. If the slave area is too dry, adjust it's maximum time to 10% more. If the area is too wet, decrease it by the same percentage. In both cases, the area should be rechecked after another few weeks, with readjustments made until the proper soil moisture level is achieved (Figure 5.38).

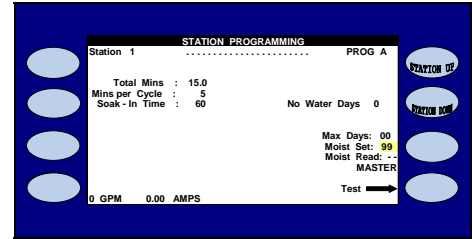


Figure 5.38

- **MOIST READ:** This entry is non-changeable. As a moisture sensor reading goes above the determined moisture set point, the controller stops irrigation. When the moisture level reading drops below the moisture set point. The controller automatically begins to irrigate more of the programmed time to where it may water the full programmed amount (Figure 5.39).

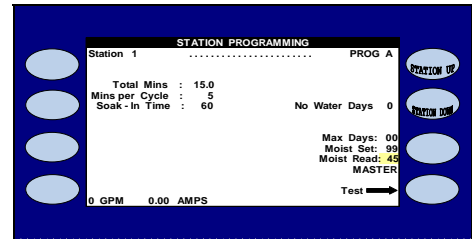





Figure 5.39

**5G.3 Test Moisture Sensor**

1.  Press the **TEST** Menu key to test the station that you are currently on.
2.  If you want to test a different station press the **STATION UP** or **STATION DOWN** keys to the right of the display screen.
3.  Press the **MANUAL** Menu key.

**Note:** This will only test the station selected, but will not get a reading from the moisture sensor.

If you want to retrieve a current reading from the moisture sensor,

The MANUAL IRRIGATION screen (Figure 5.40).

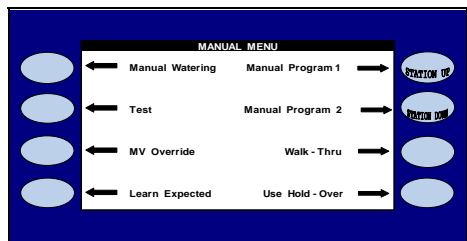


Figure 5.40

4. Press the **TEST** Menu key.

The VALVE TESTING screen is displayed (Figure 5.41).

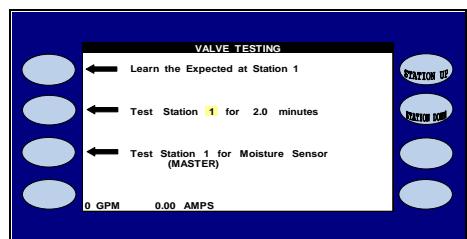


Figure 5.41

5. Press the blue **ARROW** keys to move the cursor to the **TEST STATION # FOR MOISTURE SENSOR** Entry (Figure 5.42).

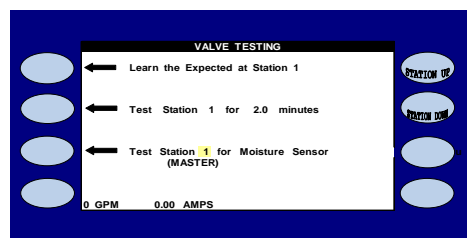


Figure 5.42

6. Press the **PLUS** or **MINUS** key to change the station entry.

**Note:** Only Master stations can test Moisture sensor for readings.

7. Press the **TEST STATION # FOR MOISTURE SENSOR** Menu key to activate test. The screen will show “READING SENSOR ON # please wait (Less than 15 seconds)” for which ever station you selected. After a brief test the **STATION PROGRAMMING** screen will appear with the Moisture Sensor reading displayed (Figure 5.43).

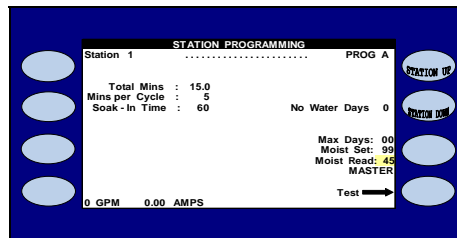


Figure 5.43

**THIS CONCLUDES THE MOISTURE SECTION**

**5H. ET STATE / COUNTY / CITY**

This section of the controller is only available if using budgets, or daily ET by program, and is used for:

- Selecting pre-programmed State, County & City monthly ET values.
- Setting your own State, County & City monthly ET values.

**5H.1 ET State/County/City setup**

From the WEATHER SETUP screen (Figure 5.2).







1. Press the **ET STATE/COUNTY/ CITY** Menu key.

The REFERENCE ET NUMBERS screen is displayed (Figure 5.44).



Figure 5.44



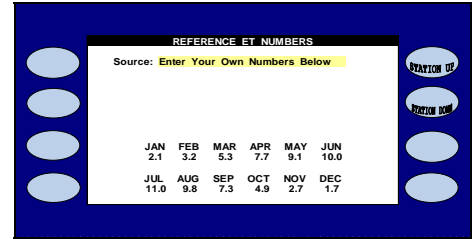
2.  Press the blue **ARROW** keys to move the cursor to the State entry (Figure 5.45).
3.  Press the **PLUS** or **MINUS** key to change the State.
4.  Press the blue **ARROW** keys to move the cursor to the County. (Figure 5.45).
5.  Press the **PLUS** or **MINUS** key to change the County.
6.  Press the blue **ARROW** keys to move the cursor to the City. (Figure 5.45).
7.  Press the **PLUS** or **MINUS** key to change the City.

As explained in the (ET and Rain Tables) portion of this guide, historical ET is used as a back up to daily ET, or it can be used as the source data to drive the program if real time ET is not used. In either case, you would want to use historical ET for the area you are located in. The ET2000e controller stores historical ET information for several states / counties, and numerous cities. Select the area that most closely represents your location (Figure 5.45)






**Figure 5.45**

You can also choose to enter your own ET numbers. If you have selected to enter your own numbers, you will be allowed to edit the numbers under each month (Figure 5.46).



**Figure 5.46**

8.  Press the blue **ARROW** keys to select a setting.
9.  Press the **PLUS** or **MINUS** keys to change the setting.
10.  Press the **MAIN MENU** key to return to the MAIN MENU screen (Figure 5.1).

**THIS CONCLUDES THE ET STATE/COUNTY/CITY SECTION**

## SECTION 6: REPORTS

The reports section of the controller is used to view the following report information:

- This Month / Last Month History
- 24 Month History
- Hold-Over
- ET & Rain Tables
- Alerts
- Station History
- Use versus Budget
- Live screens

### 6A. THIS MONTH / LAST MONTH

The This Month / Last Month report allows you to view water usage in Gallons, Hundreds of Cubic Feet, or by time used on each station for the current and last month, in the following categories:

- Irrigation
- Test and Manual
- Non-Controller usage

1. Press the **MAIN MENU** key.

From The MAIN MENU screen (Figure 6.1):

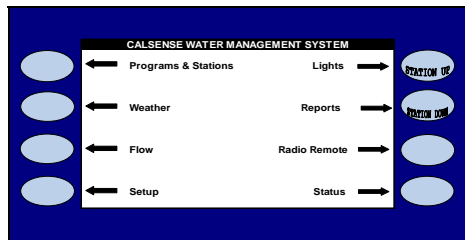


Figure 6.1

2. Press the **REPORTS** Menu key.

The REPORTS menu screen is displayed (Figure 6.2).

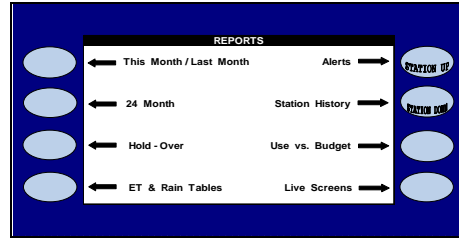


Figure 6.2

3. Press the **THIS MONTH / LAST MONTH** Menu key.

The THIS MONTH / LAST MONTH TOTALS screen is displayed (Figure 6.3)

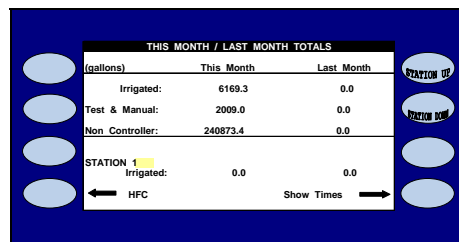


Figure 6.3


4. Press the **PLUS** or **MINUS** keys to select the desired station.
5. Press the **HFC** Menu key to change the information to Hundreds of Cubic Feet.
6. Press the **GALLONS** Menu key to change information back to Gallons.
7. You can also view Time in Minutes for each station by pressing the **SHOW TIME** Menu key.
8. To change the information back to Water Usage press the **SHOW WATER USE** Menu key.

**THIS CONCLUDES THE THIS MONTH / LAST MONTH SECTION**

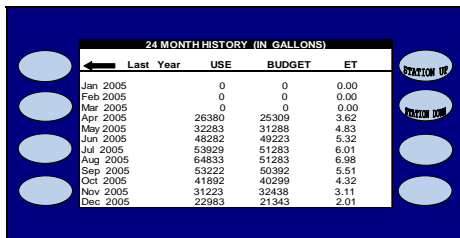
**6B. 24 MONTH**

The 24 Month report shows the amount of water used, budgeted (if budgets are enabled), and ET (if ET enabled) for the last 24 months.

From the REPORTS menu screen (Figure 6.2):

1.  Press the **24 MONTH** Menu key.

The 24 MONTH History screen is displayed (Figure 6.4)





	Last Year	USE	BUDGET	ET
Jan 2005	0	0	0	0.00
Feb 2005	0	0	0	0.00
Mar 2005	0	0	0	0.00
Apr 2005	26380	25309		3.62
May 2005	32283	31288		4.83
Jun 2005	49282	49223		5.32
Jul 2005	53929	51283		6.01
Aug 2005	64833	51283		6.98
Sep 2005	53222	50392		5.51
Oct 2005	41892	40299		4.32
Nov 2005	31223	32438		3.11
Dec 2005	22883	21343		2.01

**Figure 6.4**

The report is listed in three columns:

- **USE:** The amount of water used (gallons).
- **BUDGET:** The amount of water allocated in the budget.
- **ET:** The amount of ET for the month.

2.  Press the **LAST YEAR** Menu key to access last year's information.
3.  Press the **THIS YEAR** Menu key to go back to this year's information

**Note:** These entries can be viewed in Hundreds of Cubic Feet also.

**THIS CONCLUDES THE 24 MONTH SECTION**

**6C. HOLD-OVER**

Hold-Over occurs if the controllers irrigation cycle is forced to end before it has finished. Any unfinished irrigation will be saved as Hold-Over time. The controller will then try to use up this hold over time during subsequent irrigation cycles when programmed to do so.

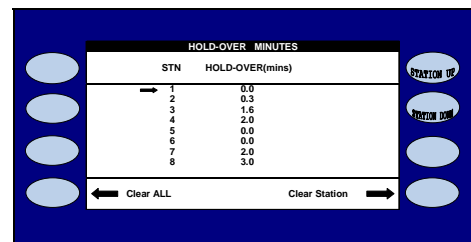
The Hold-Over section of the controller allows you to:

- Set positive or negative individual hold over time per station.
- Clear an individual stations hold-over time.
- Clear all station hold over times on controller.

From the REPORTS menu screen (Figure 6.2):





1.  Press the **HOLD-OVER** Menu key.

The HOLD-OVER screen is displayed (Figure 6.5).



STN	HOLD-OVER(mins)
1	0.0
2	0.3
3	1.6
4	2.0
5	0.0
6	0.0
7	2.0
8	3.0

**Figure 6.5**


2.  Press the **STATION UP / STATION DOWN** Menu key to view each station assigned.
3.  Press the **PLUS** or **MINUS** keys to change station values.
4.  Press the **CLEAR STATION** Menu key to clear all hold over for that particular station.
5.  Press the **CLEAR ALL** menu key to clear all stations at one time.

**THIS CONCLUDES THE HOLD-OVER SECTION**

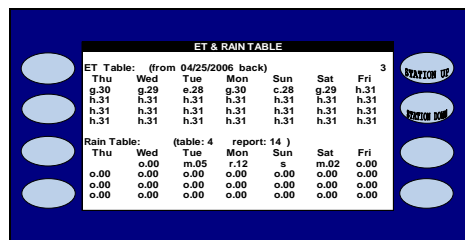
## 6D. ET & RAIN TABLES

The ET & Rain Table section of the controller allows you to look at the last consecutive 28 days of ET and Rain data.

From the REPORTS menu screen (Figure 6.2):

1.  Press the **ET & RAIN TABLES** Menu key.

The ET & RAIN TABLE screen is displayed (Figure 6.6).



ET & RAIN TABLE						
ET Table: (from 04/25/2006 back)						
Thu	Wed	Tue	Mon	Sun	Sat	Fri
g.30	g.29	e.28	g.30	c.28	g.29	h.31
h.31	h.31	h.31	h.31	h.31	h.31	h.31
h.31	h.31	h.31	h.31	h.31	h.31	h.31
h.31	h.31	h.31	h.31	h.31	h.31	h.31
Rain Table: (table: 4 report: 14 )						
Thu	Wed	Tue	Mon	Sun	Sat	Fri
o.00	o.00	m.05	r.12	s	m.02	o.00
o.00	o.00	o.00	o.00	o.00	o.00	o.00
o.00	o.00	o.00	o.00	o.00	o.00	o.00
o.00	o.00	o.00	o.00	o.00	o.00	o.00

Figure 6.6

### 6D.1 Reports / ET & Rain Table (ET)

The ET Table (Figure 6.6) shows daily ET numbers (measured in inches) stored in the controller. These numbers are used to determine the amount of irrigation to be applied to each station and can be generated from the following sources:

- o Automatically generated by an ET Gage wired to the controller.
- o Automatically generated by a Campbell Scientific weather station.
- o Automatically shared from another controller connected to an ET Gage using Calsense Command Center software. (Controllers must have communication capabilities to share ET).
- o Shared from another controller in an (-FL) chain.
- o Historical ET which is automatically entered into the ET Table when Daily ET is enabled, and remains in the table until it is replaced by real time ET from an ET gage or manually edited by the user.
- o Manually edit the ET Table.

The ET table stores the last 28 days of ET numbers. In the example in Figure 6.6 the ET table has a combination of Historical ET, actual real-time ET and user edited ET. The letter next to each number indicates how the number got into the ET Table:

**h – Historical:** This means the (ET) number was retrieved from the historical (ET) table.

**g – ET Gage:** This means the (ET) number was retrieved from an actual real-time (ET) gage.

**e – Edited:** This means the (ET) number was edited at the controller by a user.

**c – Central:** This means the central created the (ET) value due to the real-time (ET) value being below the minimum (ET) set by the user.

Prior to irrigation, the controller will read the number in the ET table and use it to recalculate the irrigation run times for each station.

### 6D.2 Reports / ET & Rain Table (Rain)

The Rain Table (Figure 6.6) is where the controller stores rainfall numbers (measured in inches). The numbers in this table can be generated from the following sources:

- o Automatically generated by a Rain Bucket wired to the controller.
- o Automatically generated by a Campbell Scientific weather station.
- o Automatically shared from another controller connected to a Rain Bucket using Calsense Command Center software. (Controllers must have communication capabilities to share rain).
- o Shared from another controller in a (-FL) chain.

**o – Original:** This value is zero (no usable rain), it has no effect on irrigation run times.

**m – Below minimum:** The below minimum value is measured rain that is not enough to offset irrigation run times.

**r – Usable rain:** This value is rain that is used to offset irrigation run times.

**s – Shutdown:** This means that irrigation was stopped due to rain reaching the maximum allowed and being shared with this controller.

The usable rain in the Rain Table is used to reduce each stations irrigation run times as determined by the precipitation rate. It is determined by settings programmed at the Rain Bucket setup screen at the controller. When scheduled irrigation is set to occur, the controller will use up the usable rain first by the amount of time scheduled to irrigate for each station. Until the usable rain is used up, there will be no irrigation. This will continue until all of the rain is used up at which time the irrigation will start again.

**(Table: 0 Reports: 0):** These two values appear in (Figure 6.6) and are defined as follows:

- **Table:** Shows the amount of usable rain pulses recorded during the last hour period, that will be applied to irrigation.
- **Reports:** Shows the amount of total rain, during the last one hour period.

**Note:** The number in the upper right hand corner of the screen (represented by a 3 in Figure 6.6) is the total recorded ET gage pulses in the last 24 hours.


**THIS CONCLUDES THE ET & RAIN TABLES SECTION**

**6E. ALERTS**

Alerts are a chronological listing of each individual event that has taken place, or changes that have been made to the controller. They can be viewed at the controller physically or obtained from the controller via communication. The Alerts section of the controller allows you to view the controller alerts in the following arrangements:

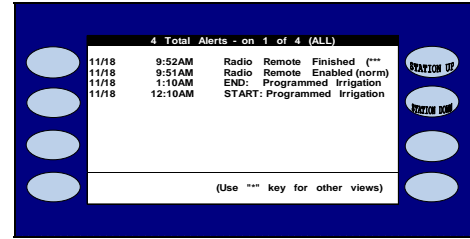
- All Alerts.
- Weather.
- Communications
- Changes (*alterations made by the key pad or use of Command Center software*).
- Irrigation.
- Status View.
- Go To Top (*Returns the highlight cursor to the top of the current list of alerts being viewed*).

From the REPORTS menu screen (Figure 6.2):


1.  Press the **ALERTS** Menu key.

**Note:** If the “ALERTS TO SEE” menu key is available on the STATUS screen when the ALERTS MENU key is pressed it will cause the MOST RECENT ALERTS screen to come up, if not the ALERTS screen will appear as in figure 6.7.

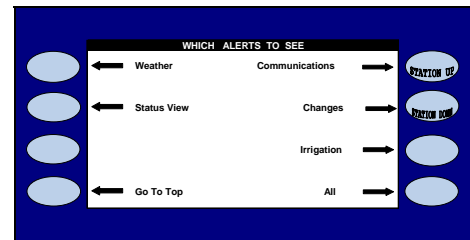
The ALERTS screen is displayed (Figure 6.7).




**Figure 6.7**

2.  Press the **PLUS** or **MINUS** keys to scroll up and down the list.

**Note:** Press the **STAR** key to access the **WHICH ALERTS TO SEE** screen which will give you a presorted view of the alerts based on alert type (Figure 6.8).

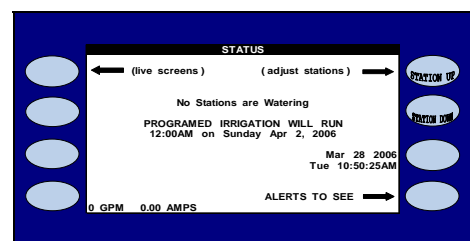


**Figure 6.8**

3.  Press the appropriate Menu key to access the alerts that you want to see.

**Note:** Alerts can also be accessed when the “ALERTS TO SEE” menu key appears on the STATUS screen (Figure 6.9).

**Note:** From the STATUS screen pressing the ALERTS TO SEE menu key will allow you to view the alerts listed under the STATUS VIEW arrangement (Figure 6.9).



**Figure 6.9**

**THIS CONCLUDES THE ALERTS SECTION**

## 6F. STATION HISTORY

The Station History report section of the controller allows you to view individual station irrigation information which include the following:

- Date and time irrigated
- Program station assigned to
- Number of cycles
- Programmed minutes
- Minutes applied
- Inches applied
- High flow limit
- Low flow limit
- Actual flow
- Minutes of Hold-Over
- Applicable Flag letter alerts (See Enclosure 2)

From the REPORTS menu screen (Figure 6.2):

1. Press the **STATION HISTORY** Menu key.

The STATION HISTORY screen is displayed (Figure 6.10).

STATION 1 HISTORY						
Date & Time	PRG	CYC	PROG		APPLIED	
			MIN	MIN	MIN	GAL
11/21 2:20PM	A	1	4.0	4.0	96	
11/20 2:20PM	A	1	4.0	4.0	96	
11/18 2:20PM	A	1	4.0	4.0	96	
11/14 2:20PM	A	1	4.0	4.0	96	
11/13 2:20PM	A	1	4.0	4.0	96	
11/11 2:20PM	A	1	4.0	4.0	96	
11/07 2:20PM	A	1	4.0	4.0	96	
11/07 2:20PM	A	1	4.0	4.0	96	

Figure 6.10

2. Press the **PLUS** or **MINUS** keys to scroll up and down the screen to view additional information.
3. Press the **PAGE LEFT** Menu key to view the next screen (Figure 6.11).

STATION 1 HISTORY						
Date & Time	-- FLOW --			MOISTURE		
	HI	GPM	LO	SET	READ	FLAG
11/21 2:20PM	19	24	29	99	41	
11/20 2:20PM	19	24	29	99	41	
11/19 2:20PM	19	24	29	99	41	
11/17 2:20PM	19	24	29	99	41	
11/16 2:20PM	19	24	29	99	41	
11/10 2:20PM	19	24	29	99	41	
11/09 2:20PM	19	24	29	99	41	
11/08 2:20PM	19	24	29	99	41	

Figure 6.11

4. Press the **PAGE RIGHT** Menu key to view the previous screen (Figure 6.10).

**THIS CONCLUDES THE STATION HISTORY SECTION**

## 6G. USE VS. BUDGET

The Use Vs. Budgets option is only available if budgets are turned on in the controller under the weather menu.

This section of the controller allows you to view the predicted outcome for the month based on your current controller settings.

From the REPORTS menu screen (Figure 6.2)

1. Press the **USE VS. BUDGET** Menu key.

The PERFORMANCE TO BUDGET screen is displayed (Figure 6.12).

PERFORMANCE TO BUDGET	
April Budget :	18383 gal
Use From Start of Month :	9866 gal
Expected for April :	12851 gal

NOTES:  
 1) Use & Expected are Scheduled plus Test plus Manual.  
 2) The Expected use takes into account the irrigation schedule along with your Test and manual usage pattern.

Figure 6.12

**Note:** You can press the **STAR** key to change the view on the screen from Gallons to Hundreds of Cubic Feet and back again.


**THIS CONCLUDES THE USE VS. BUDGET SECTION**

**6H. LIVE SCREENS**

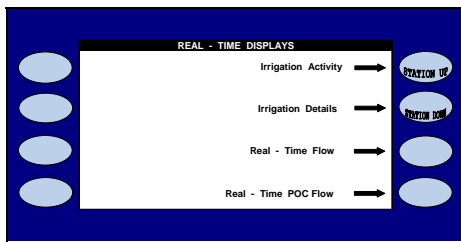
This section of the controller allows you to view:

- Current Irrigation activity.
- Current Irrigation Details.
- Current Real-Time flow.
- Current Real-Time POC information.

From the REPORTS menu screen (Figure 6.2).

1.  Press the **LIVE SCREENS** Menu key.

The REAL-TIME DISPLAYS screen is displayed (Figure 6.13).

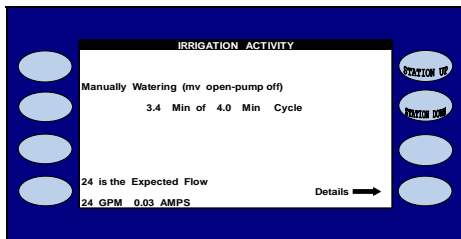


**Figure 6.13**


**6H.1 Irrigation Activity**

1.  Press the **IRRIGATION ACTIVITY** Menu key.

The IRRIGATION ACTIVITY screen is displayed (Figure 6.14).





**Figure 6.14**

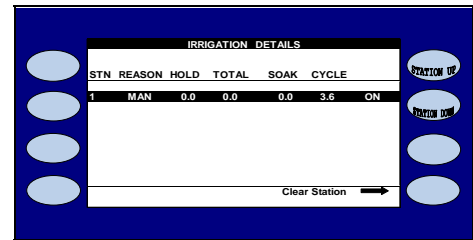
2.  Press the **DETAILS** Menu key to access the IRRIGATION DETAILS screen (Figure 6.15).

**6H.2 Irrigation Details**



From the REPORTS menu screen (Figure 6.2):

1.  Press the **LIVE SCREENS** Menu key to access the REAL-TIME DISPLAYS screen (Figure 6.13)
2.  Press the **DETAILS** Menu key to access the IRRIGATION DETAILS screen (Figure 6.15).

**Note:** From here you can view the IRRIGATION DETAILS screen for each station currently irrigating, testing, manually watering, waiting, or soaking.



**Figure 6.15**

3.  Press the **PLUS** or **MINUS** keys to highlight the station that you want to clear.
4.  Press the **CLEAR** Menu key to clear the highlighted station (Figure 6.16).



**Note:** Clearing a station will cease the operation for that station delegated on that particular line entry.

**6H.3 Real-Time Flow**

Real time flow allows the user to view the following:

- System flow rate
- Average flow rates
- Expected flow rate
- Flow meters attached to each controller in the chain and the rate at which it is currently flowing
- Whether the system is stable or unstable
- Master Valve is open or closed
- The number of valves that are currently on
- Number of controllers in the chain

From the REPORTS menu screen (Figure 6.2):

5.  Press the **LIVE SCREENS** Menu key to access the REAL-TIME DISPLAYS screen (Figure 6.13)
6.  Press the **REAL TIME FLOW** Menu key.

The REAL-TIME FLOW screen is displayed (Figure 6.16)

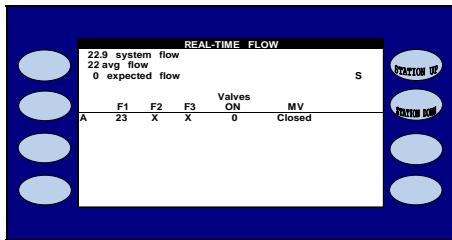




Figure 6.16

#### 6H.4 Real-Time POC Flow

Real time POC flow allows the user to view the following information for points of connection and is only available with the (-F) option.

- Used for irrigation.
- Master Valve state.
- Master Valve status.
- In use time remaining.

From the REPORTS menu screen (Figure 6.2).

1.  Press the **LIVE SCREENS** Menu key to access the REAL-TIME DISPLAYS screen (Figure 6.13)
2.  Press the **REAL TIME POC FLOW** Menu key.

The REAL-TIME POC FLOW screen is displayed (Figure 6.17)

If all three POC settings are used with irrigation the screen will appear as shown below: (Figure 6.17).

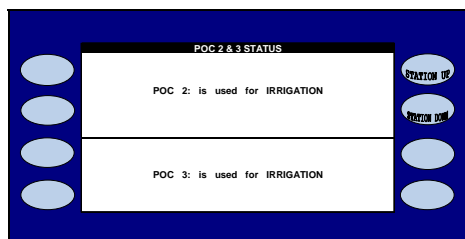


Figure 6.17

If POC 2 and/or POC 3 are used for non-irrigation purposes (See Section 4 FLOW / 4B POC (MV & FM) for setup instructions), the screen will appear as shown in (Figure 6.18).

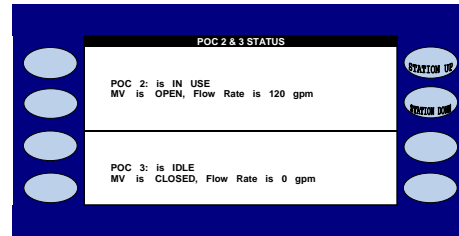


Figure 6.18

**POC x is :** This setting shows whether the POC is IN USE or IDLE. These are dictated by the POC schedule.

**Master Valve State:** This setting shows whether the Master Valve for this POC is currently OPEN or CLOSED.

**Flow Rate is:** This shows the current flow rate (in gallons per minute) for this point of connection.

**THIS CONCLUDES THE LIVE SCREENS SECTION**




**SECTION 7: LIGHTS (-L)**

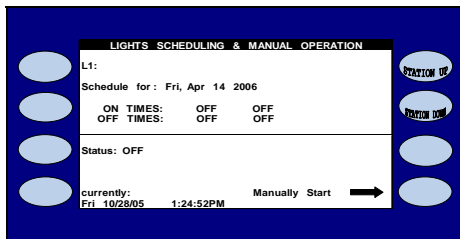
**7A. PROGRAMMING A LIGHTS SCHEDULE**

You can program up to four (4) individual light programs, with two (2) different start and stop times, each and a rolling two (2) week schedule. Only available on controllers with the (-L) option.


From the MAIN MENU screen:

1.  Press the **LIGHTS** Menu key.

The LIGHTS SCHEDULING & MANUAL OPERATION screen is displayed (Figure 7.1)






**Figure 7.1**


2.  Press the **PLUS** or **MINUS** keys to scroll through the four (4) light program screens. They are designated as L1:, L2:, L3: and L4:

**Note:** The lights program names can be changed by the user via Command Center software.

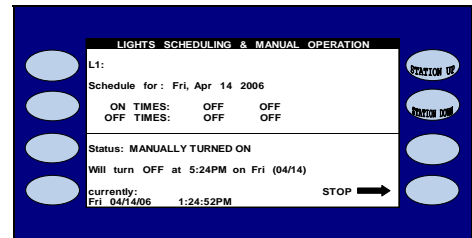
Once you have selected the lights program that you want to use.

3.  Press the blue **ARROW** keys to highlight the date entry. You can select any date between now and two weeks from today's date.
4.  Press the blue **ARROW** keys to highlight the ON TIMES (Two per program), and OFF TIMES (two per program).
5.  Adjust the times by using the **PLUS** or **MINUS** keys.


**7B. TESTING A LIGHTS CIRCUIT**

1.  You can also test a light circuit by pressing the **MANUALLY START** Menu key.

This will activate the program selected for four hours from the time you pressed the button (Figure 7.2).



**Figure 7.2**

2.  To end the light program test, press the **STOP** key.

**Note:** The **STOP** Menu key can also be pressed to end the lights program in progress.

**THIS CONCLUDES THE LIGHTS SECTION**

## SECTION 8: RADIO REMOTE (-RRe)

### 8A. ENABLE RADIO REMOTE

If the Radio Remote Control option is installed on a controller (-RRe), the **RADIO REMOTE** Menu key will be available at the MAIN MENU screen.

From the MAIN MENU screen:

1. Press the **RADIO REMOTE** Menu key.

The **ADD CONTROLLER TO HANDHELD** screen will appear (Figure 8.1).

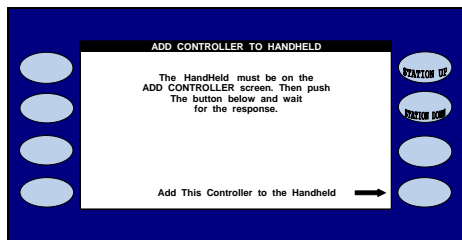


Figure 8.1

#### ON THE HANDHELD RADIO REMOTE:

2. Press the **ON/RESUME** button.
3. Scroll down to **CHANGE LIST** (Figure 8.2).



Figure 8.2

4. Press the **SELECT** button.
5. Move the cursor to **ADD VIA CONTROLLER** (Figure 8.3).

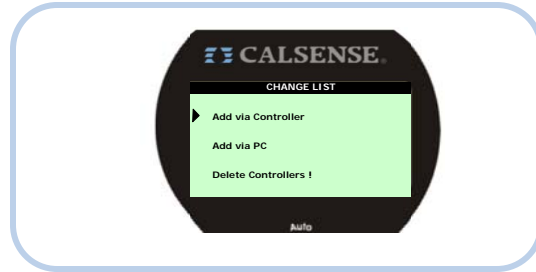


Figure 8.3

6. Press the **SELECT** button.

#### AT THE CONTROLLER:

The **ADD THIS CONTROLLER TO THE HANDHELD** screen will change to display "OK Controller has been added" (Figure 8.2).

7. Press the **ADD THIS CONTROLLER TO THE HANDHELD** Menu key to activate the controller Radio Remote.

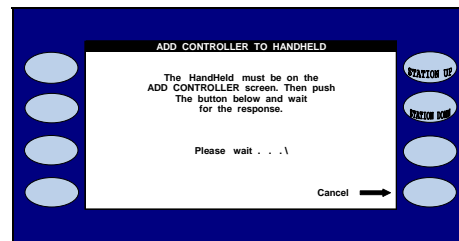


Figure 8.2


8. Press the **CANCEL** Menu key to end this application.

**THIS CONCLUDES THE RADIO REMOTE SECTION**

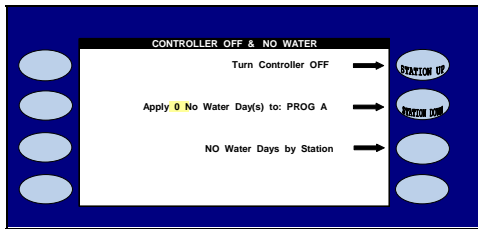
**SECTION 9: NO WATER KEY**

**9A. NO WATER KEY DESCRIPTION**

From this screen you can turn the controller off, set No Water Days for all stations by, program, or for individual stations. This affects Manual Program 1 & 2, Scheduled Irrigation, and Scheduled Hold-Over. Once the No Water Days elapse, the station(s) will start to irrigate according to their irrigation schedule. The No water setting can be from 1 to 31 days.



1.  Press the **NO WATER** key.

The **CONTROLLER OFF & NO WATER** screen is displayed (Figure 9.1).






**Figure 9.1**

**9A.1 Turn controller OFF**





1.  Press the **TURN CONTROLLER OFF** Menu key to turn off the controller and immediately return to the STATUS screen.
2.  To turn the controller back on, press the **PUSH TO TURN ON** Menu key located at the STATUS screen.

**9A.2 Apply No Water Days to program**

From the **CONTROLLER OFF & NO WATER DAYS** screen (Figure 9.1).

1.  Press the blue **ARROW** keys to move the highlight to the number of No Water Days setting.
2.  Press the **PLUS** or **MINUS** keys to set the desired number of No Water Days.
3.  Press the blue **ARROW** keys to

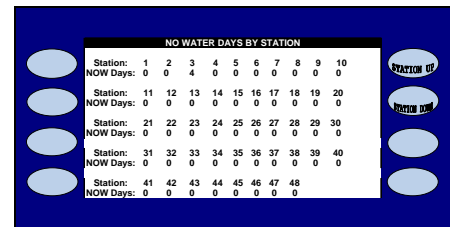
highlight which program to set the No Water Days for.

4.  Press the **PLUS** or **MINUS** keys to select the desired program (or all stations).
5.  Press the **APPLY NO WATER DAYS** Menu key. ( In Figure 9.1, 11 stations on Program B will be turned off for three consecutive days.
6.  To turn a program back on at anytime, return to the **TURN CONTROLLER OFF & NO WATER** screen and set the No Water Days to zero (0).
7.  Press the **APPLY NO WATER DAYS** Menu key.



**9A.3 No water days by station**

1.  Press the **NO WATER DAYS BY STATION** Menu key.

The **NO WATER DAYS BY STATION** screen is displayed (Figure 9.2).



**Figure 9.2**

2.  Press the blue **ARROW** keys to highlight which station to set the No Water Days on.
3.  Press the **PLUS** or **MINUS** keys to select the desired amount of no water days per station.


**Note:** No Water Days take effect immediately. Stations will count down consecutively each time the program they are assigned to crosses a Start Time. This occurs even if a selected day of the week is **not** a Water Day.

**THIS CONCLUDES THE NO WATER SECTION**

## SECTION 10: MANUAL KEY

The Manual section of the controller is used for:

- Manual Watering stations
- Testing individual stations
- Master Valve Override
- Learning station expected flow rates
- Manual Programs
- Walk-Thru
- Use Hold Over

1.  Press the **MANUAL** key.

The MANUAL MENU screen is displayed (Figure 10.1).

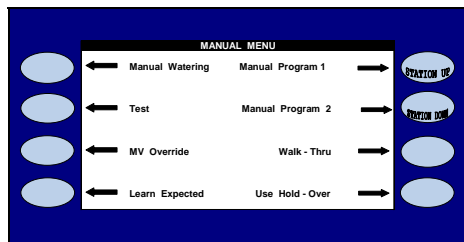



Figure 10.1

### 10A. MANUAL WATERING

The Manual Watering section of the controller is used to manually water individual stations, or all stations within a program using total timed irrigation or cycle and soak.

1.  Press the **MANUAL WATERING** Menu key.

The MANUAL IRRIGATION screen is displayed (Figure 10.2).

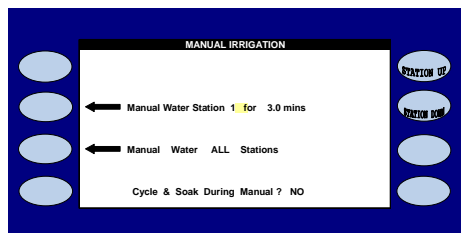




Figure 10.2

### 10A.1 Manual Water a Station

From the MANUAL IRRIGATION screen (Figure 10.2):

1.  Press the **PLUS** or **MINUS** keys to change the station number.
2.  Press the **MANUAL WATER STATION # FOR ### MINS** Menu key.

The IRRIGATION FOR STATION # screen is displayed (Figure 10.3).

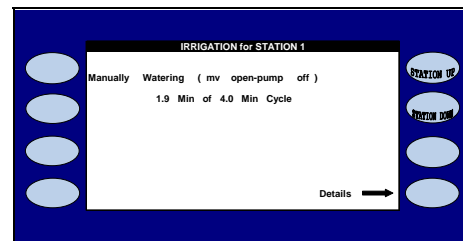





Figure 10.3

-  **Note:** Pressing the **DETAILS** Menu key will take you to the IRRIGATION DETAILS screen where you can view, or clear the station. (See Section 6 REPORTS / IRRIGATION DETAILS).

### 10A.2 Manual Water a Program


From the MANUAL IRRIGATION screen (Figure 10.2):

1.  Press the **PLUS** or **MINUS** keys to change the program selection.
2.  Press the **MANUAL WATER PROG # STATIONS** Menu key to activate watering of all stations for selected program.

The IRRIGATION FOR STATION # screen will appear for each station as it irrigates (Figure 10.3).


**10A.3 Cycle and Soak during Manual**

From the MANUAL IRRIGATION screen (Figure 10.2):

- 
 Press the **PLUS** or **MINUS** keys to change the **CYCLE & SOAK DURING MANUAL** setting (Figure 10.2).

**Note:** If set to YES, this will use the Soak-In-Time and Minutes Per Cycle setting for each station individually. IF “NO” then it will water the Total Minutes time without soaking.


**THIS CONCLUDES THE MANUAL WATERING SECTION**

 **10B. TEST**

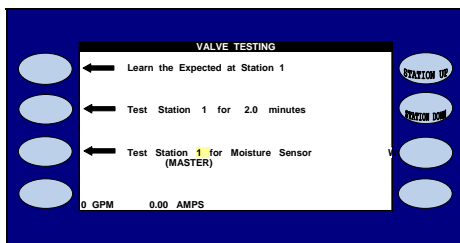
The Test section of the controller is used to:

- Learn expected flow rates at a station.
- Test an individual station.
- Test moisture sensors *(If enabled)*.

From the MANUAL MENU screen (Figure 10.1):

- 
 Press the **TEST** Menu key.

The VALVE TESTING screen is displayed (Figure 10.4)





**Figure 10.4**

**10B.1 Learn the Expected at a Station**


The Learn expected option on the controller will learn the expected flow rate for each station on each program selected. Only available if a flow meter is installed.

From the VALVE TESTING screen (Figure 10.4):

- 
 Press the **PLUS** or **MINUS** keys to change the station number.
- 
 Press the **LEARN THE EXPECTED AT STATION #** Menu key to Learn The Expected flow rate for the Station selected.



**Note:** The IRRIGATION FOR STATION # screen will come on for the station selected while it learns the expected flow (Figure 10.3)

**Note:** This will cause the station to turn on.

- 
 Press the **DETAILS** Menu key to view, or clear the selected station.

**10B.2 Test a Station**

From the VALVE TESTING screen (Figure 10.4):

- 
 Press the **PLUS** or **MINUS** keys to change the Station number.
- 
 Press the **TEST STATION # FOR X.X MINUTES** Menu key to test the selected station. The time is adjustable from 0.1 to 20.0 minutes.

**10B.3 Test a Station Moisture Sensor (See Section 5 Moisture)**

**THIS CONCLUDES THE TEST SECTION**

 **10C. MV OVERRIDE**

The Master Valve Override section of the controller is used for:

- Opening the Master Valve for a specific amount of time.
- Setting up a weekly schedule for the Master Valve to be opened.

From the Manual Menu screen (Figure 10.1):

1. Press the **MASTER VALVE OVERRIDE** Menu key.

The MASTER VALVE OVERRIDE screen is displayed (Figure 10.5).

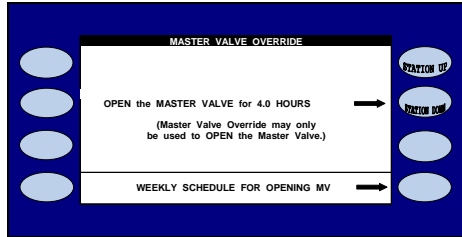


Figure 10.5

**10C.1 Open Master Valve for Specified Time**

From the MASTER VALVE OVERRIDE screen (Figure 10.5).

1. Press the **PLUS** or **MINUS** keys to change the Open Master Valve time.
2. Press the **OPEN MASTER VALVE FOR #.## HOURS** Menu key to activate the time period.

**10C.2 Weekly Schedule for Opening Master Valve**

From the MASTER VALVE OVERRIDE screen (Figure 10.5).

1. Press the **WEEKLY SCHEDULE FOR OPENING MV** Menu key.

The SCHEDULE OPENING THE MASTER VALVE screen is displayed (Figure 10.6).

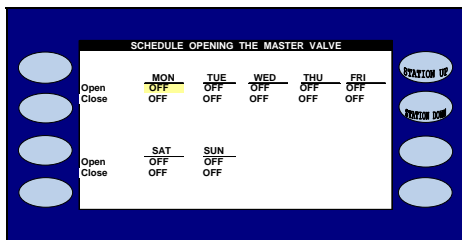


Figure 10.6

2. Press the **PLUS** or **MINUS** keys to change the "Open master valve time".
3. Press the blue **ARROW** keys to change from the open and close entry and to change from one day to the next.

**Note:** This is a rolling schedule that will repeat every week.

**Note:** All daily settings will have to be set to OFF to terminate the weekly schedule.

**THIS CONCLUDES THE MASTER VALVE OVERRIDE SECTION**

**10D. LEARN EXPECTEDS**

Learn expecteds allows you to learn the expected flow rate for each station. This will occur at the next scheduled irrigation for that station.

From the MANUAL MENU screen (Figure 10.1).

1. Press the **LEARN EXPECTED THE EXPECTED FLOW RATES** screen (Figure 10.7).

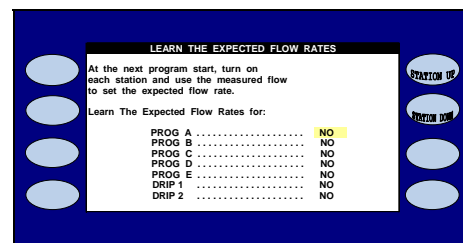


Figure 10.7


2. Press the **PLUS** or **MINUS** keys to change the program setting.
3. Press the blue **ARROW** keys to change from one program to the next.

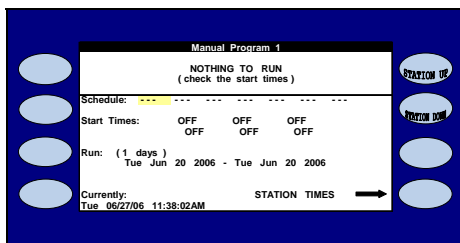
**THIS CONCLUDES THE LEARN EXPECTEDS SECTION**

**10E. MANUAL PROGRAM 1**




The Manual Program section of the controller provides an alternative to regularly scheduled irrigation that performs the day to day requirements for watering landscapes. Typical use of manual programs might include over seeding, and fertilizing.

From the MANUAL MENU screen (Figure 10.1).


1.  Press the **MANUAL PROGRAM 1** Menu key to access the MANUAL PROGRAM 1 screen (Figure 10.8).




**Figure 10.8**


2.  Press the **PLUS** or **MINUS** keys to turn a specific day of the week ON, or OFF.
3.  Press the blue **ARROW** keys to change from one day to the next.
4.  Press the **PLUS** or **MINUS** keys to set a specific Start Time.

**Note:** You can set up to six different Start Times per Manual Program.

5.  Press the blue **ARROW** keys to change from one Start time to the next.

Now select the amount of days that you want the program to run.

6.  Press the blue **ARROW** keys to highlight the Run setting.

7.  Press the **PLUS** or **MINUS** keys to set the amount of days that you want the program to run. (The End date will change automatically).

**Note:** If you want the schedule to begin on a later date you will have to adjust the number of run days to accommodate the change, and then change the Start date.

**10F. MANUAL PROGRAM 2 (See MANUAL PROGRAM 1)**

**THIS CONCLUDES THE MANUAL PROGRAMS SECTION**

**10G. WALK-THRU**

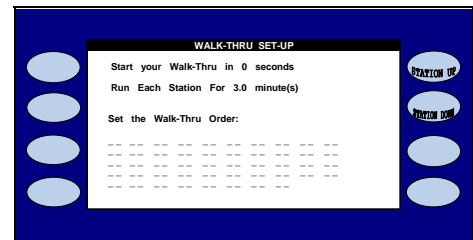
The Walk-Thru program is used to perform a user orchestrated wellness check on selected stations in the controller by selecting:

- The countdown time to activation (*5 seconds to 15.0 minutes*).
- The order in which the stations activate.
- The run time limit for each station (*0.1 seconds to 15.0 minutes*).


From the MANUAL MENU screen (Figure 10.1).

1.  Press the **WALK-THRU** Menu key.





The WALK-THRU screen is displayed (Figure 10.9).




**Figure 10.9**

2.  Press the **PLUS** or **MINUS** keys to set the time in seconds that you want the Walk-Thru to begin in.

**Note:** Time must be set from 0.1 seconds to 15.0 minutes.

3.  Press the blue **ARROW** keys to highlight the RUN EACH STATION FOR ##.# Minute(s).
4.  Press the **PLUS** or **MINUS** keys to set the amount of time that you want each station to run for. The same time will be set for each station selected.
5.  Press the blue **ARROW** keys to highlight the individual station slots.
6.  Press the **PLUS** or **MINUS** keys to enter the number for the station that you want to come on in that slot.

**Note:** A single station cannot be entered into multiple slots.

7.  Press the **BEGIN COUNTDOWN** Menu key (Figure 10.10).

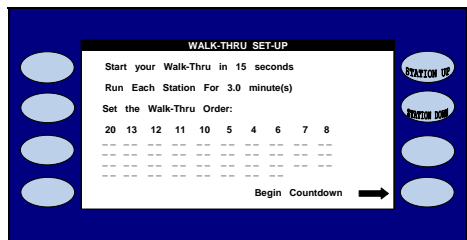



Figure 10.10

8.  Press the **STOP TIMER** Menu key to halt the countdown.

**Note:** If the controller is off the countdown will not begin.


**Note:** When countdown has completed the controller will take you to the Irrigation details screen.

**THIS CONCLUDES THE WALK-THRU SECTION**

 **10H. USE HOLD-OVER**

Hold-Over time is generated whenever scheduled irrigation has hit the Stop time. The controller will first try and use up any hold-over in the table after scheduled irrigation has finished, but before the Stop Time has been reached. The Use Hold-Over feature allows the user to schedule a specific time and day(s) to try and use up any hold-over in the table.

From the MANUAL MENU screen (Figure 10.1).

1.  Press the **USE HOLD-OVER** Menu key.

The MANUAL USE OF HOLD-OVER screen is displayed (Figure 10.11).

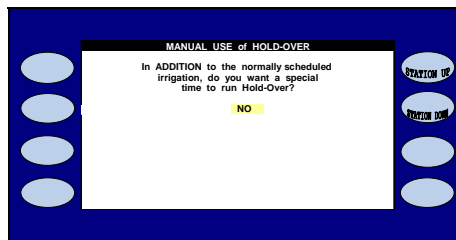



Figure 10.11

2.  Press the **PLUS** or **MINUS** keys to select whether or not you want to use Hold-Over. If YES is selected, the screen will change to reveal the set up parameters (Figure 10.12).

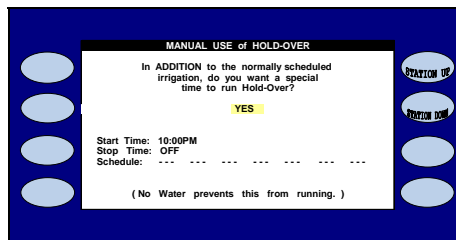









Figure 10.12

3.  Press the blue **ARROW** keys to highlight the Start Time.



4.  Press the **PLUS** or **MINUS** keys to set the time that you want the Hold-Over irrigation to begin.
5.  Press the blue **ARROW** keys to highlight the Stop Time.
6.  Press the **PLUS** or **MINUS** keys to set the Stop Time.
7.  Press the blue **ARROW** keys to highlight the Schedule days.
8.  Press the **PLUS** or **MINUS** keys to turn on the days that you want the Hold-Over to be used on.
9.  Press the **MAIN MENU** key to return to the MAIN MENU screen.

**CAUTION:**

No Water Days prevents the Hold-Over program from Running.

**THIS CONCLUDES THE USE HOLD-OVER SECTION**

### SECTION 11: (-FL) FLOWSENSE®

The Calsense *FLOWSENSE®* option allows the user to manage an irrigation system that has one or more points of connection and one or more controllers sharing these points of connection. *FLOWSENSE®* affords the user the following:

- No scheduling conflicts between multiple controllers
- Eliminates relays when sharing pumps or master valves with several controllers
- Manages the number of valves ON based upon flow capacities
- Water management capabilities with or without a flow meter
- Pump performance managed for electrical savings
- Setup in the field without a central computer



**Note:** The above listed items are only feasible with two or more controllers in a communications chain.

#### 11A. MULTIPLE CONTROLLER COMMUNICATION SETUP

**Note:** A chain is defined as a set of controllers connected together via the same communications type and / or frequency.

**Note:** All of the controllers in the chain must be able to communicate with each other via (-SR) Spread Spectrum Radio, or (-M) Hardwired.

From the MAIN MENU screen:

1.  Press the **SETUP** Menu key.
2.  Press the **COMMUNICATIONS** Menu key.

The COMMUNICATION ADDRESS screen is displayed (Figure 11.1).

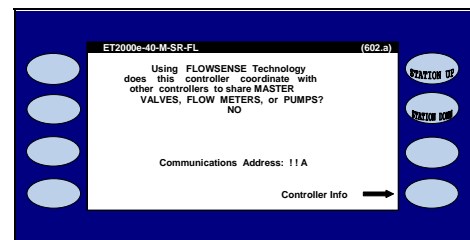





Figure 11.1

3.  Press the **PLUS** or **MINUS** keys to change the NO to a YES setting.

**Note:** Each controller in the communications chain must have the (-FL) option and will have to be set to YES.

4.  Press the blue **ARROW** keys to move the cursor to the next question. NUMBER OF CONTROLLERS IN SYSTEM ?.

5.  Press the **PLUS** or **MINUS** keys to change the amount of controllers in the system (Figure 11.2).

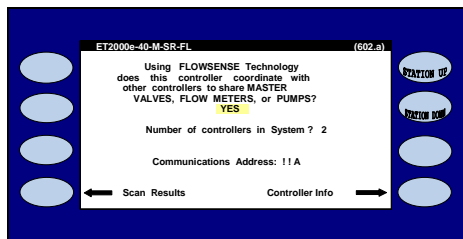



Figure 11.2

Repeat the process described above until all three characters are set (The character furthest to the right must be a letter).

**Note:** With multiple controllers one of the controllers must be the Master with an address ending in a Capital "A". All other controllers will have addresses ending in B, C, D, etc. No two controllers can have the same exact address when communicating to the same central computer. The Master controller must be the controller communicating back to the central.

**If you desire to look at the controller's communications information:**

6.  Press the **CONTROLLER INFO** Menu key to go to the PART & SERIAL NUMBERS screen (Figure 11.3).

**Note:** This will allow you to look at the controller's ROM version, Baud Rates, Part number, and Command center software version required to communicate with this controller.

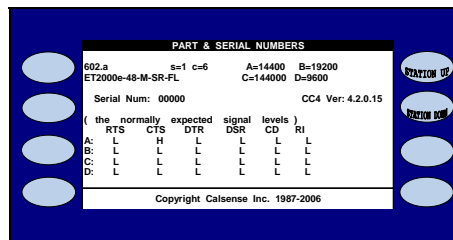




Figure 11.3

You will have to perform a Controller Scan:

7.  Press the **BACK** key.
8.  Press the **SCAN RESULTS** Menu key.

The COMMUNICATIONS SCAN RESULTS screen is displayed (Figure 11.4).

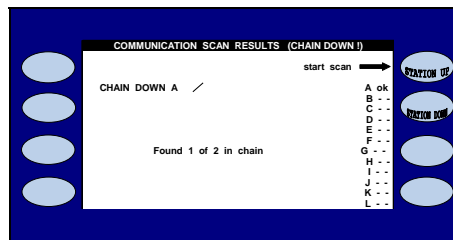



Figure 11.4

9.  Press the **START SCAN** Menu key to begin the scan.

**Note:** The controller will scan each controller in the chain.

- B " - - " symbol indicates that the controller in the chain was unsuccessful at communicating (The Master did not find the "B" controller).
- B " ok " symbol indicates that the controller was found and is currently communicating with the master controller (the "A" controller).

**Note:** The scan can only be performed at the Master controller in the FLOWSENSE® chain. Also the "Number of controllers in chain." can only be adjusted at the master controller.

Example:  
Number of controllers in chain 5

Controller	position in chain	communications address
Master controller	A	!!A
Slave controller	B	!!B
Slave controller	C	!!C
Slave controller	D	!!D
Slave controller	E	!!E

**THIS CONCLUDES MULTIPLE CONTROLLER COMMUNICATIONS SETUP**

**11B. MULTIPLE CONTROLLER FLOW SETUP**

Setting up a *FLOWSENSE®* chain involves making adjustment entries to the Master controller and every controller that has a flow meter or master valve is physically installed on. Make sure you are familiar with the following subsections of Section 4 FLOW:

- A. Flow Meter setup.
- B. Line Fill & Valve close times.
- C. Master Valve.
- D. Pump.
- H. Alert Actions.


in addition to the following instructions:

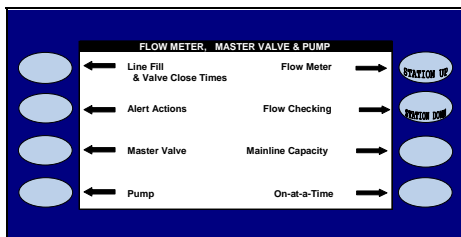
**11B.1 Mainline Capacity**

System capacity is defined by the maximum flow rate of water that your system can operate at during irrigation.

Note: This setting will have to be adjusted at the Master Controller (the controller with the letter “A” as the right most character in its communications address).

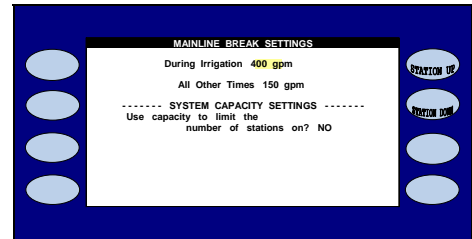
From the FLOW METER, MASTER VALVE & PUMP screen is displayed.

1.  Press the **MAINLINE CAPACITY** Menu key (Figure 11.5).





**Figure 11.5**

The **MAINLINE BREAK SETTINGS** screen is displayed (Figure 11.6).




**Figure 11.6**

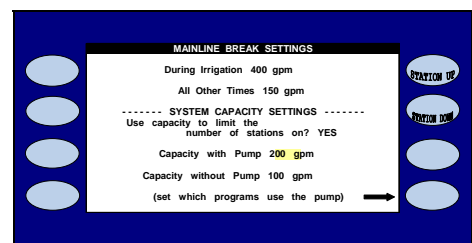
2.  Press the blue **ARROW** keys to move the cursor to the **DURING IRRIGATION** gpm.
3.  Press the **PLUS** or **MINUS** keys to change the number.

Use the same method to change the **ALL OTHER TIMES** number.

- **DURING IRRIGATION:** The during-irrigation number is the mainline break number used while the controller is irrigating.
- **ALL OTHER TIMES:** The all other times number is the mainline break number used when the controller is not irrigating.
- **USE CAPACITY TO LIMIT THE NUMBER OF STATIONS ON ?:** If you want to use capacity to limit the number of stations on in the system change to YES.

This will open up the portion of the screen dealing with Capacity with or without Pump (Figure 11.7).

4.  Press the **PLUS** or **MINUS** key to change the capacity numbers.



**Figure 11.7**

**Capacity with pump:** When a program irrigates by use of pump the GPM limit set will not be exceeded.

**Capacity without pump:** When a program irrigates without the use of a pump the GPM limit will not be exceeded.

**Note:** Pump and non-pump programs will not run simultaneously on the same controller / system.

- If you are using a pump and did not select SET WHICH PROGRAMS TO USE PUMP in the pump section of this manual then press the **SET WHICH PROGRAMS TO USE THE PUMP** Menu key (Figure 11.7).

The WHICH PROGRAMS USE THE PUMP screen is displayed (Figure 11.8).

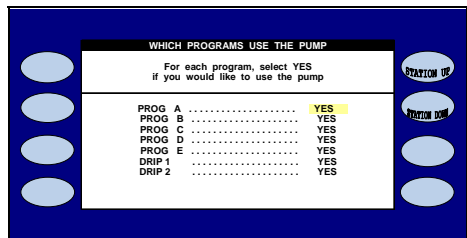


Figure 11.8

- Press the blue **ARROW** keys to move the cursor to the program desired.

**Note:** The default setting is set to YES on all programs, which means that the controller's pump output will be activated whenever a station on any program is activated.

Set the Pump Output Enabled setting to NO. If the Pump Output Enabled setting is set to NO on a program, the pump output will not activate when a station on that program is activated.

- Press the **PLUS** or **MINUS** keys to change any program setting.

### 11.B.2 Flow Checking

Flow checking allows you to have the controller compare the flow of each station during irrigation to the learned expected flow and alert you of any problems.

**Note:** You must have a flow meter turned on in the controller, or in the chain / system.

**Note:** This setting will have to be adjusted at the Master Controller (The controller with the letter "A" as the right most character in its communications address). Once set, all of the controllers in the chain will conform to this setting.

From the FLOW METER, MASTER VALVE & PUMP screen.

- Press the **FLOW CHECKING** Menu key.

The FLOW CHECKING screen is displayed (Figure 11.9).

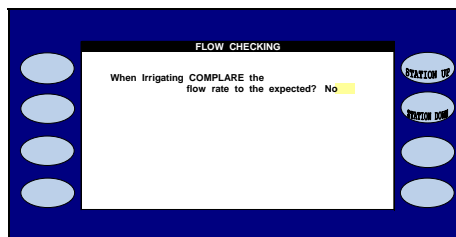


Figure 11.9

This will open up the ALLOWABLE portion of the screen if you select YES to the WHEN IRRIGATING COMPARE THE FLOW TO THE EXPECTED ? question (Figure 11.10).

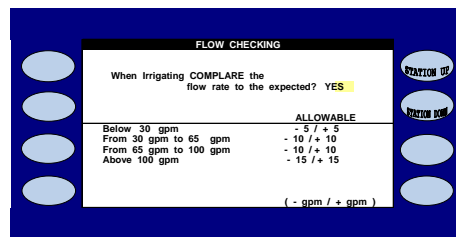


Figure 11.10

- Press the blue **ARROW** keys to change the Allowable settings.

The default settings are:

**BELOW:** -5 / +5  
**FROM / TO:** -10 / +10  
**FROM / TO:** -10 / +10  
**ABOVE:** -15 / +15

**Note:** The above settings are defaulted in the controller and can be changed by the user.



4. To change the settings press the **PLUS** or **MINUS** keys for any number to change the setting.

**Below:** This section allows you to enter the fluctuation range for the low end of your normal operating flow. Use the (-) and (+) entries to set the range.

*Example:*

If you set the below limit at 30 gallons per minute.  
 and set your limit at -5/+5,

You will be alerted if the flow at the low end of the scale fluctuates by more than 5 gallons per minute in either direction.

That is less than 25 gpm or more than 35 gpm

**1<sup>st</sup> From / To:** This section allows you to set the fluctuation limits for the lower range of your medium flowing valves. In this box you want to enter the normal operating range of water flow. Then in the (-) and (+) blocks enter the range of fluctuation that you deem normal.

*Example:*

If you set the below limit at 30 gpm to 65 gpm.  
 and set your limit at -10/+10,

You will be alerted if the flow at the low end of the scale fluctuates by more than 10 gallons per minute in either direction.

That is less than 20 gpm or more than 75 gpm

**2<sup>nd</sup> From / To:** This section allows you to set the fluctuation limits for the high end of your medium flowing valves. In this box you want to enter the

normal operating range of water flow. Then in the (-) and (+) blocks enter the range of fluctuation that you deem normal.

*Example:*

If you set the below limit at 65 gpm to 100 gpm.  
 and set your limit at -10/+10,

You will be alerted if the flow at the low end of the scale fluctuates by more than 10 gallons per minute in either direction.

That is less than 55 gpm or more than 75 gpm

**Above:** This section allows you to enter the fluctuation range for the high end of your normal operating flow. Use the (-) and (+) entries to set the range.


**Note:** You will want to set this allowable range up a little wider due to the amount of water flow.

*Example:*

If you set the above limit at 100 gallons per minute.  
 And set your limit at -15/+15.

You will be alerted if the flow at the high end of the scale fluctuates by more than 15 gallons per minute in either direction.

That is less than 85 gpm or more than 115 gpm

4.  Press the **BACK** key to return to the FLOW METER, MASTER VALVE, & PUMP screen (Figure 11.5).

**11B.3 On – At - A - Time**

The On-At-a-Time section of the controller is used to set up the number of valves that you want to come on simultaneously within a program, and also within the system.

**Note:** These settings need to be entered at each controller in the chain.

From the FLOW METER, MASTER VALVE & PUMP screen (Figure 11.5).



1. Press the **ON-AT-A-TIME** Menu key.

The STATIONS ON-AT-A-TIME screen is displayed (Figure 11.11).

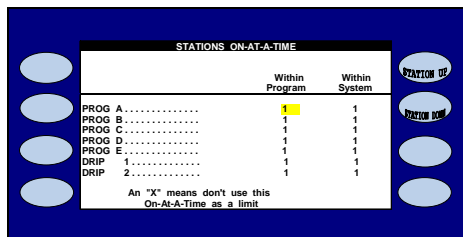


Figure 11.11

2. Press the blue **ARROW** keys to move the cursor to the Program and Within Program setting desired.

**Note:** The default setting is set to 1 on all programs and within system.

3. Press the **PLUS** or **MINUS** keys for any number to change the setting.

- **WITHIN PROGRAM:** This section allows you to choose the amount of valves that you want to set as a limit to come on at a time within a program.
- **WITHIN CONTROLLER:** This section allows you to choose the amount of valves that you want to set as a limit to come on at a time within the controller.

*Example:*

	Within Program	Within Controller
Program A	1	2
Program B	1	2

This example allows the user to set up one (1) valve on at a time for Programs A and B. The controller will allow both Programs to have one (1) valve each run simultaneously for a total of two (2) on within controller.

*Example:*

	Within Program	Within Controller
Program A	1	1
Program B	3	3

This example allows the user to set up one (1) valve on at a time for Programs A. The controller will only allow one valve to operate while program A is running. Program B is set up to operate 3 valves on at a time, and will only operate up to three valves when Program B is running.


4. Press the **BACK** key to return to the FLOW METER, MASTER VALVE, & PUMP screen (Figure 11.5).

**THIS CONCLUDES THE FLOWSENSE® SECTION**

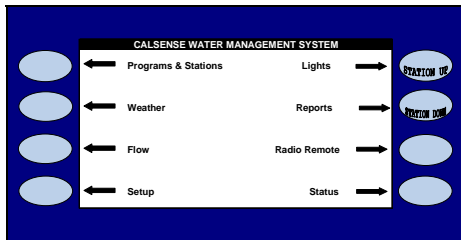
**SECTION 12: (-F) OPTION:**

All models of Calsense controllers that have a (-F) option can use up to three (3) separate Points of connection.


**12A. Point of Connection 1 (POC 1)**

1.  Press the **MAIN MENU** key.

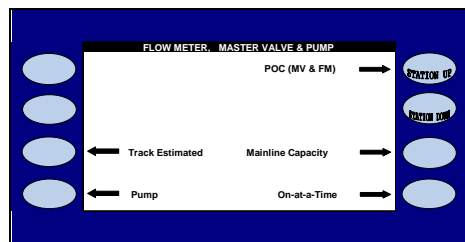
The MAIN MENU screen is displayed (Figure 12.1).



**Figure 12.1**

2.  Press the **FLOW** Menu key.

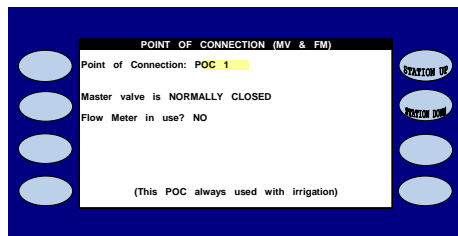
The FLOW METER, MASTER VALVE & PUMP screen is displayed (Figure 12.2).



**Figure 12.2**



3.  Press the **POC (MV & FM)** Menu key.

The POINT OF CONNECTION screen is displayed (Figure 12.3).



**Figure 12.3**

**Note:** POC 1 is set for use with irrigation always and cannot be changed.

4.  Press the blue **ARROW** key to highlight MASTER VALVE IS setting.
5.  Press the **PLUS** or **MINUS** keys to change the MASTER VALVE IS setting.

The Master Valve default setting is for a normally closed Master Valve. There are two (2) settings,

- **NORMALLY CLOSED:** A normally closed Master Valve is in the closed position until voltage is applied to open it.
- **NORMALLY OPEN:** A normally open Master Valve is in the open position until voltage is applied to close it.

**Note:** Be sure to select the correct type of Master Valve installed, if it is incorrect the Master Valve will close whenever a station is irrigated and no water will flow when a valve is turned on.

If using a FMBX flow meter see:

1. FMBX flow meter setup

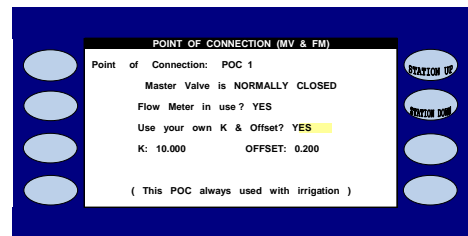
If using a regular flow meter see:

2. Regular flow meter setup





If using a combination of FMBX along with regular style flow meters you will have to select "USE YOUR OWN K & OFFSET NUMBERS" for all three flow meter entries.

**12A.1 FMBX flow meter setup**

If the flow meter installed on the system is a Calsense FMBX, change the "Use your own K & Offset" to YES, (The screen will appear as shown in Figure 12.4).



**Figure 12.4**

1.  Press the blue **ARROW** keys to move the cursor to the K: setting.
2.  Press the **PLUS** or **MINUS** keys to change the number.
3.  Press the blue **ARROW** keys to move the cursor to the OFFSET: setting.
4.  Press the **PLUS** or **MINUS** keys to change the number.



**Note:** The two settings that must be set are the K value and the Offset. If you know these values enter them now. If not, Call Calsense at 1-(800)-572-8608 for assistance.

The ranges for these two settings are:

- **K:** 0.200 to 800.00
- **OFFSET:** 0.000 to 1.000

**12A.2 Regular flow meter setup**

If the answer to Use your own K & Offset is NO.

1.  Press the blue **ARROW** keys to move the cursor to the FLOW METER SIZE: setting.
2.  Press the **PLUS** or **MINUS** keys to change the flow meter type.

Refer to the chart (Figure 12.5), to choose the correct flow meter type.

MODEL NUMBER	SIZE
FM-1	1" PLASTIC FLOW METER
FM-1B	1" BRASS FLOW METER
FM-1.25B	1 1/4" BRASS FLOW METER
FM-1.5	1 1/2" PLASTIC FLOW METER
FM-1.5B	1 1/2" BRASS FLOW METER
FM-2	2" PLASTIC FLOW METER
FM-2B	2" BRASS FLOW METER
FM-3	3" PLASTIC FLOW METER

Figure 12.5

 **12B. Point of Connection 2 & 3 (POC 2 & 3)**

POC 2 & 3 can be set up individually for use with irrigation or for non-irrigation use. They can also have individual settings for the Master Valves type, and Flow Meter type and size used.

**12B.1 POC Use with irrigation**

When setting up Point of Connection 2 or 3 for use with irrigation the programming steps are the same as used for Point of Connection 1. Each point of connection will be set up individually, and the IS THIS POC USED WITH IRRIGATION? setting will be set to YES (See figure 12.6).

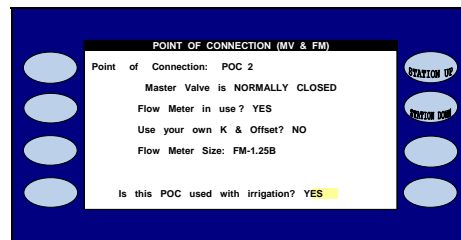


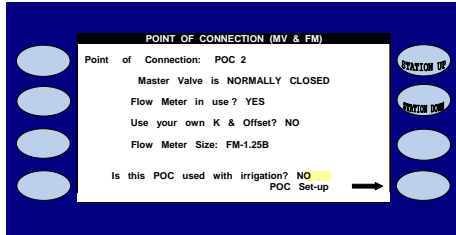
Figure 12.6

**12.B.2 POC Use with Non-irrigation**

When setting up Point of Connection 2 or 3 for use with Non-irrigation the programming steps are a little different. Each point of connection will be set up individually, and the IS THIS POC USED WITH IRRIGATION? Setting will be set to NO for any Point of Connection that is not used with irrigation and requires an individual schedule.

The POINT OF CONNECTION (MV & FM) screen is displayed (Figure 12.7).

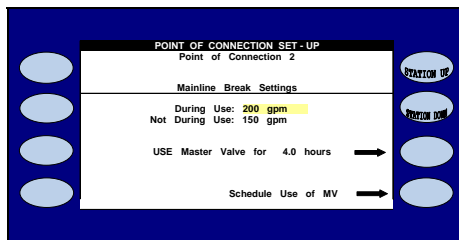







**Figure 12.7**

1.  Press the **POC SETUP** Menu key.

The POINT OF CONNECTION SET-UP screen is displayed (Figure 12.8).



**Figure 12.8**

2.  Press the **PLUS** or **MINUS** keys to change the DURING USE: number.
3.  Press the blue **ARROW** keys to move the cursor to the NOT DURING USE: setting.
4.  Press the **PLUS** or **MINUS** keys to change the NOT DURING USE: number.

**During Use:** This setting is defined as the gallons per minute that you expect your system to flow at during the time period scheduled. Allow for normal fluctuation readings when setting the number.

**Not During Use:** This setting is defined as the gallons per minute that you expect your system to flow at during non-scheduled periods of time.




The range for both of these settings are:

**1 to 4000 gpm**

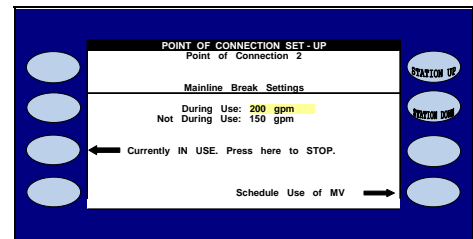
**12B.3 Use Master Valve for x.xx hours**

This setting can be used to open a normally closed Master Valve on Point of connection 2 or 3 for a period of time from 0.1 hours to 24.0 hours.

**Note:** Point of Connection has to be set up for Non-irrigation use for this screen to be available.


1.  Press the blue **ARROW** keys to move the cursor to the **USE MASTER VALVE FOR X.XX HOURS** setting.
2.  Press the **PLUS** or **MINUS** keys to change the highlighted number.
3.  Press the **USE MASTER VALVE FOR X.XX HOURS** Menu key.

The POINT OF CONNECTION SET-UP screen is displayed (Figure 12.9).



**Figure 12.9**


**Note:** If you want to discontinue this evolution use Step 4.

4.  Press the **CURRENTLY IN USE. PRESS HERE TO STOP** Menu key, to discontinue current use of POC.

**Note:** If a time is set and the **USE MASTER VALVE FOR X.XX HOURS** Menu key is pressed and left to continue. The Master Valve will close automatically after the duration elapses.

**12B.4 Schedule Use of MV**

**Note:** Point of Connection has to be set up for Non-irrigation use for this screen to be available.

1.  Press the **SCHEDULE USE OF MV** Menu key.

The MV USE: START TIME AND DURATION screen is displayed (Figure 12.10).

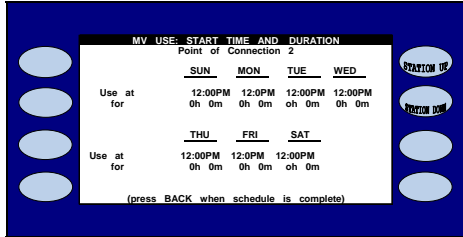






Figure 12.10

2.  Press the blue **ARROW** keys to move the cursor to the desired USE AT setting.
3.  Press the **PLUS** or **MINUS** keys to change the start time.
4.  Press the blue **ARROW** keys to move the cursor to the desired FOR setting.
5.  Press the **PLUS** or **MINUS** keys to change the amount of time in hours and minutes.

**THIS CONCLUDES THE (-F) OPTION SECTION**

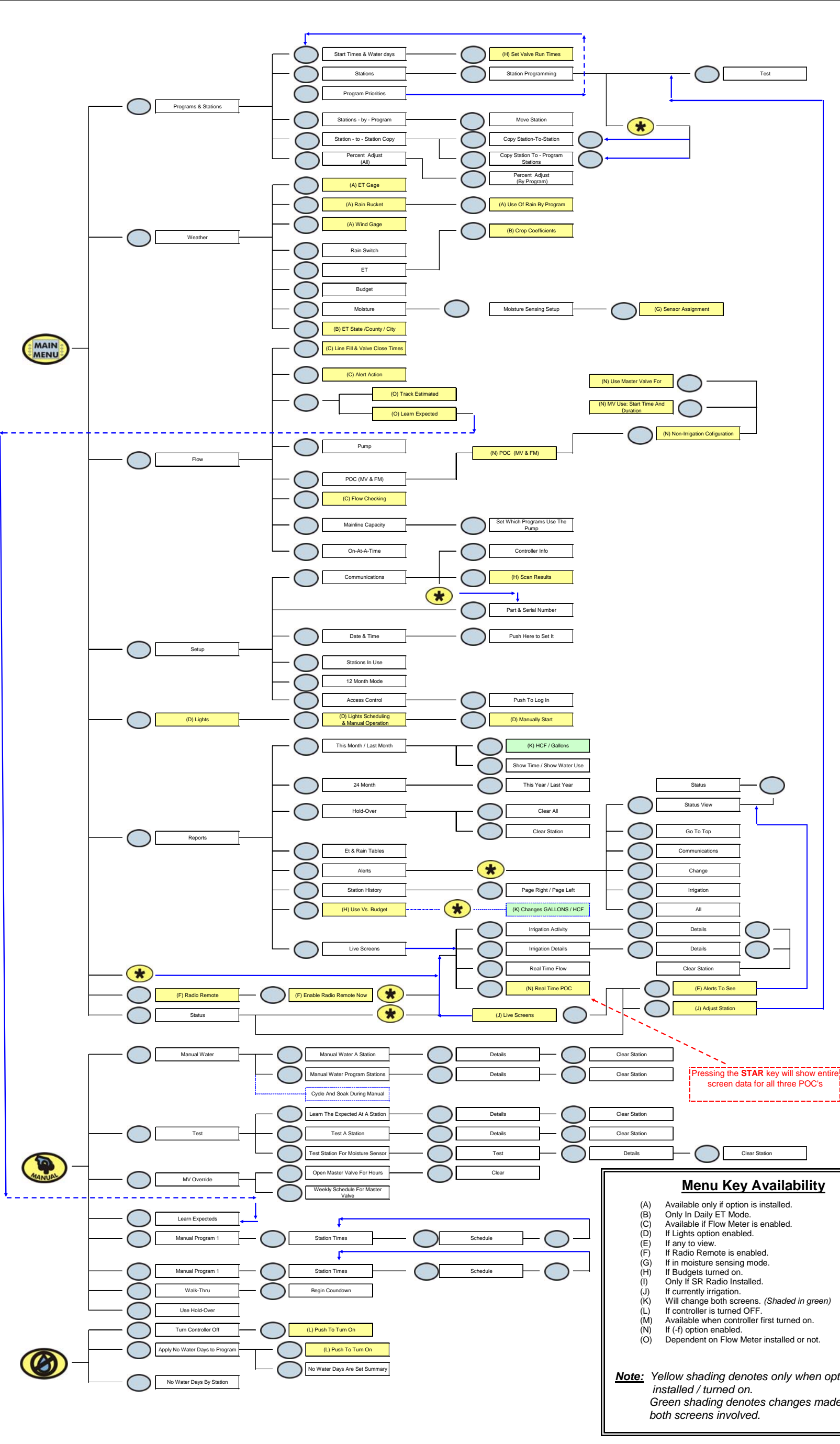
**NOTES**

Lined area for taking notes, consisting of two columns of horizontal lines.



 **MAXIMUM & MINIMUM SETTING WITHIN THE ET2000e**

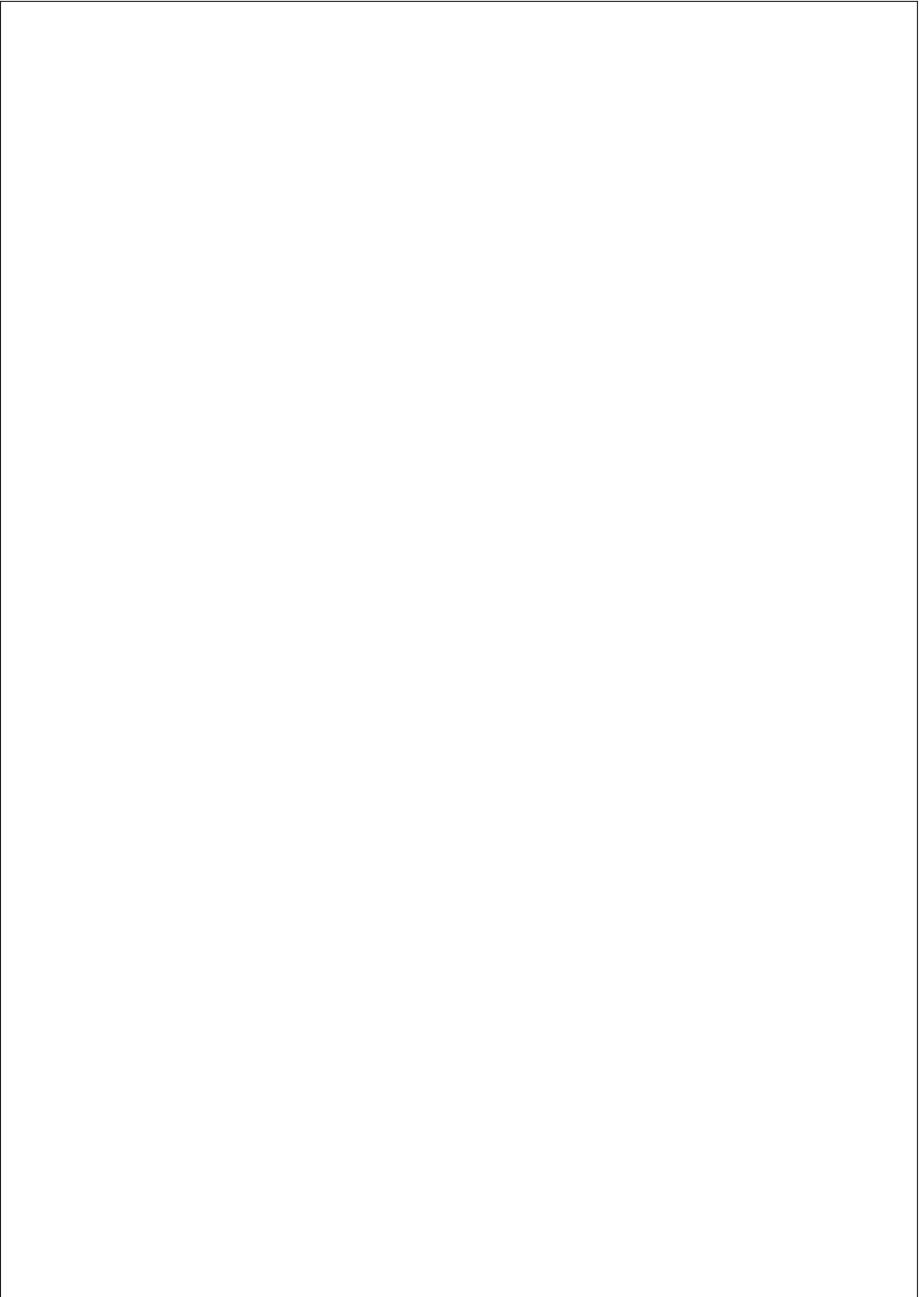
Maximum and Minimum settings within the ET2000e			
Area	Setting	Minimum	Maximum
Station Programming	Total Minutes	0.0 Minutes	999.0 Minutes
	Minutes Per Cycle	1 Minutes	255 Minutes
	Soak In Time	5 Minutes	1275 Minutes
	No Water Days	0 Days	31 Days
	Expected Flow	1 Gallons	4000 Gallons
	Area Sq / Ft	100 Sq/Ft	65000 Sq/Ft
	Max Days	0 Days	31 Days
	Moist Set	01	99
	% of ET	0 Percent	999 Percent
Percent Adjust	Adjust all Stations	-99 Percent	+200 Percent
	Adjust By Program	-99 Percent	+200 Percent
Program Priorities	Level	Low	High
Master Valve	MLB During Irrigation	1 Gallons	4000 Gallons
	MLB All Other Times	1 Gallons	4000 Gallons
	MLB During Use GPM	1 Gallons	4000 Gallons
	MLB Not During Use GPM	1 Gallons	4000 Gallons
	Schedule use for duration	1 Minute	72 Hours
	Use Master Valve for hours	0.1 Hours	24.0 Hours
Flow Meter	Flow Meter K Factor	0.000 Value	800.000 Value
	Flow Meter Offset	0.0 Value	0.200 Value
System Capacity	Capacity With Pump	1 Gallons	4000 Gallons
	Capacity Without Pump	1 Gallons	4000 Gallons
Flow Checking	From Limit	10 Gallons	4000 Gallons
	To Limit	10 Gallons	4000 Gallons
	Allowable limit Below	-2 / +2 Gallons	-200 / +200 Gallons
	From / to	-2 / +2 Gallons	-200 / +200 Gallons
	From / to	-2 / +2 Gallons	-200 / +200 Gallons
	Above	-2 / +2 Gallons	-200 / +200Gallons
On-At-A-Time	Within Program	1-4 valves, X (based on system capacity and electrical limit)	1-4 valves, X (based on system capacity and electrical limit)
	Within Controller / System	1-4 valves, X (based on system capacity and electrical limit)	1-4 valves, X (based on system capacity and electrical limit)
Line Fill	Line Fill time	30 Seconds	1800 Seconds
Valve Close	Valve Close time	30 Seconds	1800 Seconds
ET Gage	Irrigation Day is from	5:00 PM to 5:00 PM	8:00 PM to 8:00 PM
	Gage is full %	9 Percent	99 Percent
	Gage = inches	.00 Inches	.30 Inches
Rain Bucket	Stop Irrigation After Inches	0.01 Inches	2.00 Inches
	Maximum Rain in ONE Hour is	0.01 inches	2.00 inches
	Maximum Rain in 24 Hours is inches	0.01 Inches	6.00 Inches
	Let Rain Only Build up to inches	0.01 Inches	6.00 Inches
Wind Gage	Pause Irrigation MPH	11 Miles per Hour	99 Miles per Hour
	Resume Irrigation MPH	1 Miles per Hour	10 Miles per Hour
ET	Allowable % of Historical ET	10 Percent	300 Percent
ET State / County / City	Monthly Percentage	0.00 Percent	20.00 Percent
Budgets	Calculate budgets at % of ET	10 Percent	300 Percent
	Yearly budget is gallons	0 Gallons	108,000,000 gallons
	Monthly gallons	0 Gallons	9,000,000 Gallons
Hold-Over	Hold-Over Minutes	-120.0 Minutes	120.0 Minutes
Manual Water Station	Manual Water Station	0.0 Minutes	999.9 Minutes
Test	Test Station	0.1 Minutes	20.0 Minutes
	Station Minutes	0 Minutes	99 Minutes
Manual Program 1 & 2	Run Until	1 Days	999 Days
	Start your Walk-Thru in	5 Seconds	15 Minutes
Walk-Thru	Run each station for minutes	0.1 Minutes	15.0 Minutes



**Menu Key Availability**

- (A) Available only if option is installed.
- (B) Only In Daily ET Mode.
- (C) Available if Flow Meter is enabled.
- (D) If Lights option enabled.
- (E) If any to view.
- (F) If Radio Remote is enabled.
- (G) If in moisture sensing mode.
- (H) If Budgets turned on.
- (I) Only if SR Radio Installed.
- (J) If currently irrigation.
- (K) Will change both screens. *(Shaded in green)*
- (L) If controller is turned OFF.
- (M) Available when controller first turned on.
- (N) If (-) option enabled.
- (O) Dependent on Flow Meter installed or not.

**Note:** Yellow shading denotes only when option installed / turned on.  
Green shading denotes changes made will alter both screens involved.



## Flag Letter Definitions For Controller

LETTER	DESCRIPTION	DEFINITION
S	<b>Short Circuit</b>	During normally scheduled irrigation or during scheduled manual hold over a short circuit was detected. The valve is turned off and the remaining irrigation time is thrown away. At the next scheduled irrigation the valve will try again.
O	<b>No Current</b>	During normally scheduled irrigation or during scheduled manual hold-over, an open circuit was detected. This is a passive alert. The valve stayed on and completed its irrigation.
C	<b>Low Current</b>	A low current situation was detected. Not yet implemented or used.
I	<b>High Current</b>	A high current situation was detected. Not yet implemented or used.
A	<b>Tail Ends Adjustment</b>	During normally scheduled irrigation or during scheduled manual hold-over, the Tail-Ends adjustment caused a portion of the scheduled time not to run. The time to irrigate was less than 5% of the cycle time. (FYI: When the residual time is between 5% & 20% of the cycle time it is evenly divided up among the cycles that do run.)
L	<b>Low Flow</b>	During normally scheduled irrigation or during scheduled manual hold-over, flow was tested and this valve failed the <b>LOW FLOW</b> test. The action taken is controlled by the Alert Actions settings.
H	<b>High Flow</b>	During normally scheduled irrigation or during scheduled manual hold-over, flow was tested and this valve failed the <b>HIGH FLOW</b> test. The action taken is controlled by the Alert Actions settings.
U	<b>Flow Not Checked</b>	For one reason or another flow could not be checked during one of the cycles that this station ran during normally scheduled irrigation or during scheduled manual hold-over. In field service mode you will get an elaborate alert detailing the conditions that could prevent flow from being checked.
W	<b>No water</b>	The scheduled programmed irrigation did not apply any time for this station because <b>NO WATER</b> days were set.
R	<b>Rain switch</b>	The <b>RAIN SWITCH</b> caused the programmed irrigation to cut short or to not be applied at all. In addition whenever a <b>RAIN BUCKET</b> causes programmed irrigation to be affected (either through polling or sharing) this flag is set. So it's a dual use flag: used to indicate Rain Switch and Rain Bucket activities. This flag will be set if the above rain events occur during scheduled manual hold-over.
B	<b>Main Line Break</b>	A <b>MAINLINE BREAK</b> affected the programmed irrigation. Either it did not start or it was cut short when the mainline break occurred. This flag will be set if the mainline break occurs during scheduled manual hold-over.

<b>T</b>	<b>Normal Stop Time</b>	During normally scheduled programmed irrigation, we crossed the <b>HOLD OVER</b> time. The irrigation was terminated and the remaining time was added to the hold-over for that station. This flag is set during manually scheduled hold-over if during that activity we hit the manual hold-over <b>STOP TIME</b> .
<b>F</b>	<b>Controller Off</b>	The normally scheduled programmed irrigation did not apply any time for this station because the controller was set to <b>OFF</b> . This flag will be set if the controller is turned <b>OFF</b> in the middle of applying normally scheduled irrigation or scheduled manual hold-over.
<b>M</b>	<b>Moisture Sensor Caused Cycle Skip</b>	The <b>MOISTURE SENSOR</b> caused the programmed irrigation or scheduled hold-over time to be cut short. A number of cycles did not irrigate because the moisture sensor reading was equal to or above the set point. Anywhere from one cycle to all of the scheduled cycles may be curtailed. This flag is set in the master station as well as all of his slaves.
<b>X</b>	<b>Moisture Sensor Max water Days Set</b>	While using moisture sensing, <b>MAX WATER</b> was set causing this station to irrigate all of its normally scheduled irrigation- regardless of what the moisture sensor said to do.
<b>V</b>	<b>Master Valve Override</b>	The master valve was closed using <b>MASTER VALVE OVERRIDE</b> . This master valve closure either prohibited the normally scheduled irrigation from occurring or it interrupted it. This flag will be set if the master valve is closed using master valve override during scheduled manual hold-over.

## Flag Letter Definitions For Moisture sensors

<b>LETTER</b>	<b>DESCRIPTION</b>	<b>DEFINITION</b>
<b>---</b>	<b>Reading Never Taken</b>	This means the "Moisture sensor in use block" in Program Data is checked but the program in the "Use Moisture Sensor in the following program" block using this station is not checked for moisture sensor usage.
<b>R**</b>	<b>Reading Out Of Range</b>	This means the reading the controller received from the Moisture Sensor was out of the realm of 0-100 therefore out of range.
<b>F**</b>	<b>No Filtered Reading</b>	Hardware problem with the controller / moisture sensor / or field wiring
<b>S**</b>	<b>Signal Never went Away</b>	Hardware problem with the controller.
<b>O--</b>	<b>Reading Not Put In Line Yet</b>	This means that there is a Moisture Sensor assigned to this station via a program, but has not yet taken a reading.





## ET Table Codes

LETTER	DESCRIPTION	DEFINITION
<b>e</b>	<b>Edited</b>	This means the (ET) number was edited at the controller by a user.
<b>g</b>	<b>ET Gage</b>	This means the (ET) number was retrieved from actual real-time (ET).
<b>h</b>	<b>Historical</b>	This means the (ET) number was retrieved from the historical (ET).
<b>c</b>	<b>Central</b>	This means the central created the (ET) number due to the real-time (ET) being below the minimum (ET) allowed by the user.

## Rain Table Codes

LETTER	DESCRIPTION	DEFINITION
<b>o</b>	<b>Original</b>	This value is zero (no usable rain), it has no effect on irrigation run times.
<b>m</b>	<b>Below Minimum</b>	The below minimum value is measured rain but not enough to offset irrigation run times.
<b>r</b>	<b>Usable Rain</b>	This means that the number was usable rain. This value is rain that is used to offset irrigation run times.
<b>s</b>	<b>Shutdown</b>	This means that irrigation was stopped due to rain polling being shared with this controller.
<b>p</b>	<b>Polling</b>	This means weather sharing has either failed or has not occurred yet since polling shutdown occurred.

 (ENCLOSURE 4) STATION WIRING COLOR CODES



STATION	CONNECTOR COLOR	WIRE COLOR	STATION	CONNECTOR COLOR	WIRE COLOR
1	RED	BLACK	33	WHITE	BLACK
2	RED	RED	34	WHITE	RED
3	RED	WHITE	35	WHITE	WHITE
4	RED	GREEN	36	WHITE	GREEN
5	RED	ORANGE	37	WHITE	ORANGE
6	RED	BLUE	38	WHITE	BLUE
7	RED	BROWN	39	WHITE	BROWN
8	RED	YELLOW	40	WHITE	YELLOW
9	BLUE	BLACK	41	BROWN	BLACK
10	BLUE	RED	42	BROWN	RED
11	BLUE	WHITE	43	BROWN	WHITE
12	BLUE	GREEN	44	BROWN	GREEN
13	BLUE	ORANGE	45	BROWN	ORANGE
14	BLUE	BLUE	46	BROWN	BLUE
15	BLUE	BROWN	47	BROWN	BROWN
16	BLUE	YELLOW	48	BROWN	YELLOW
17	YELLOW	BLACK	<b>OUTPUT</b>	<b>CONNECTOR COLOR</b>	<b>WIRE COLOR</b>
18	YELLOW	RED	MASTER VALVE 2	ORANGE	BLACK
19	YELLOW	WHITE	MASTER VALVE 3	ORANGE	RED
20	YELLOW	GREEN	LIGHTS 1	ORANGE	WHITE
21	YELLOW	ORANGE	LIGHTS 2	ORANGE	GREEN
22	YELLOW	BLUE	LIGHTS 3	ORANGE	ORANGE
23	YELLOW	BROWN	LIGHTS 4	ORANGE	BLUE
24	YELLOW	YELLOW			
25	GREEN	BLACK	<b>FUNCTION</b>	<b>CONNECTOR COLOR</b>	<b>WIRE COLOR</b>
26	GREEN	RED	FLOW IN	BLACK	RED
27	GREEN	WHITE	FLOW OUT	BLACK	BLACK
28	GREEN	GREEN	24 VAC	BLACK	ORANGE
29	GREEN	ORANGE	COMMON	BLACK	WHITE
30	GREEN	BLUE	COMMON	BLACK	WHITE
31	GREEN	BROWN	MASTER VALVE 1	BLACK	BLUE
32	GREEN	YELLOW	PUMP	BLACK	GREEN
			RAIN SWITCH INPUT	BLACK	YELLOW

**DO NOT SHORT OUTPUTS - SEVERE DAMAGE MAY RESULT**

DATE AUG 2006 Version C Controller Output Label



2075 Corte del Nogal, Suite P, Carlsbad CA 92011  
1-(800)-572-8608 FAX: 1-(760)-438-2619  
[www.calsense.com](http://www.calsense.com)

Stock Number: PG4-IC-D2

Rev. 03/07

CHANGE 1 INCORPORATED

30 March 2007



making water work

since 1986