

# **ET2000 (500 SERIES) IRRIGATION CONTROLLER**



## **INSTALLATION**



## CONTROLLER INSTALLATION

### Physical Installation

#### **Location**

Calsense Irrigation Controllers are supplied by low voltage 24 VAC step-down transformers. The irrigation controller and transformer are housed in a weather proof metal cabinet that can be either wall mounted or mounted on a matching pedestal. The key locking door swings left and can be removed.

- In choosing a location for the irrigation controller, consideration should be given to the accessibility of the 120 volt AC power wires and the routing of the wires connecting to the irrigation control valves.
- A minimum of 2 inches of clearance above the irrigation controller is necessary for the door to be removed after installation. The door needs 11.5 inches on the left to fully open.

#### **Wall Mounting (PD-1)**

- For wall mounting, the irrigation controller should be mounted on a flat secure surface. The liquid crystal display should be slightly below eye level of the shortest users for the best viewing.
- Clearance must be given for the conduit containing the 120 volt AC power and the irrigation controller wires.

#### **Mounting the Irrigation Controller**

The Calsense Irrigation Controller must be removed from the cabinet before mounting.

- Remove the four retaining screws and tip the irrigation panel out of the cabinet.
- Carefully pull off the power connector leading from the transformer and all station wire harness connectors.
- Remove the irrigation controller from the cabinet.
- Three (3) pre-drilled mounting holes are provided in the back of the cabinet. Use these for positioning the drill holes in the wall. Attach the irrigation controller cabinet

securely to the wall using fasteners designed for mounting surface.

#### **Pedestal Mounting (PD-1)**

- The pedestal is to be mounted on a level concrete base with the top of the base at least 2 inches above grade. This base should be about 6 ½ inches by 12 inches by 11 inches deep. (see Pedestal Mounting Sheet).
- Four anchor bolts provided must be positioned in the concrete before it sets. A position template is supplied with the pedestal. (see Pedestal Mounting Sheet).
- Position any necessary sweep elbows in the concrete form (see Pedestal Mounting Sheet). Bring the 117 volt line input wiring through the concrete base in the form before pouring the concrete (see Pedestal Mounting Sheet).
- If more than one controller is to be mounted on a common base, leave 5 inches or more between the outside edges of the pedestal anchor bolt templates.

#### **CAUTION:**

**Remove Bolt positioning template before mounting enclosure.**

- Mount the pedestal over the four anchor bolts, (see figure 2), with washers and nuts provided. (IMPORTANT- tighten all four (4) nuts securely). Check that the pedestal is vertical and shim with redwood spacers if necessary.
- Open controller door, remove controller.
- Open the pedestal access panel and position the controller cabinet on the pedestal. Fasten the controller cabinet to the pedestal with mounting screws and nuts provided. (see figure 2 for position and direction screws are to be inserted).
- Replace access panel and controller.

**PD-1 Pedestal Mounting Sheet**

**PD-1 PEDESTAL MOUNTING INSTRUCTIONS**

1. The pedestal is to be mounted on a level concrete base with the top of the base at least 2" above finish grade. This base should be about 18 1/2" x 12 1/2" x 8" (Fig. 1)
2. The 4 anchor bolts provided must be positioned in the concrete before it sets. A steel mounting template is included with the pedestal (Fig. 1)
3. Position any necessary sweep ells in the concrete form. The sweep ell for the irrigation control wires should be to the right, and the sweep ell for the 117 VAC should be to the left (Fig. 1).
4. If more than one controller is to be mounted on a common base, allow a minimum space of 5" between the outside edges of the mounting templates.
5. After the concrete has set, remove the mounting template.
6. Mount the pedestal over the 4 anchor bolts (Fig. 2). Secure with the nuts and washers provided (tighten nuts securely).
7. Remove the controller panel from the controller cabinet (Fig. 2).
8. Remove the pedestal access panel and position the controller cabinet on the pedestal. Secure the controller cabinet to the pedestal using the 3 mounting bolts provided (Fig. 2).
9. Replace the pedestal access panel and controller panel.

**CONCRETE BASE FOR PEDESTAL**

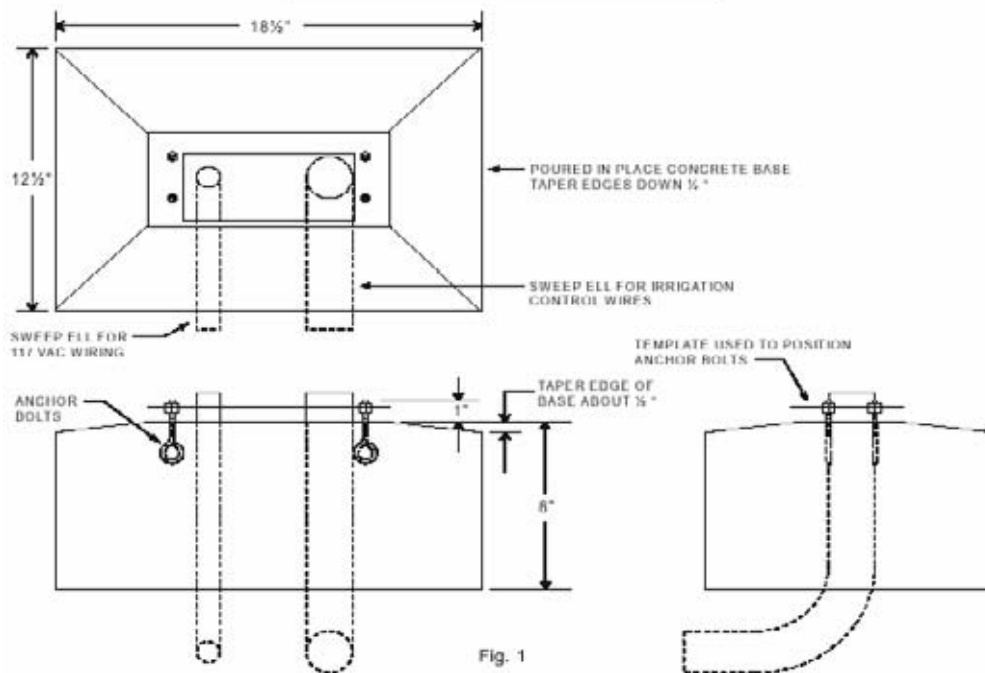

Stock No. 4007

Rev 8/01



**PD-1 Pedestal Mounting Sheet (Continued)**

**PEDESTAL AND CONTROLLER ASSEMBLY**

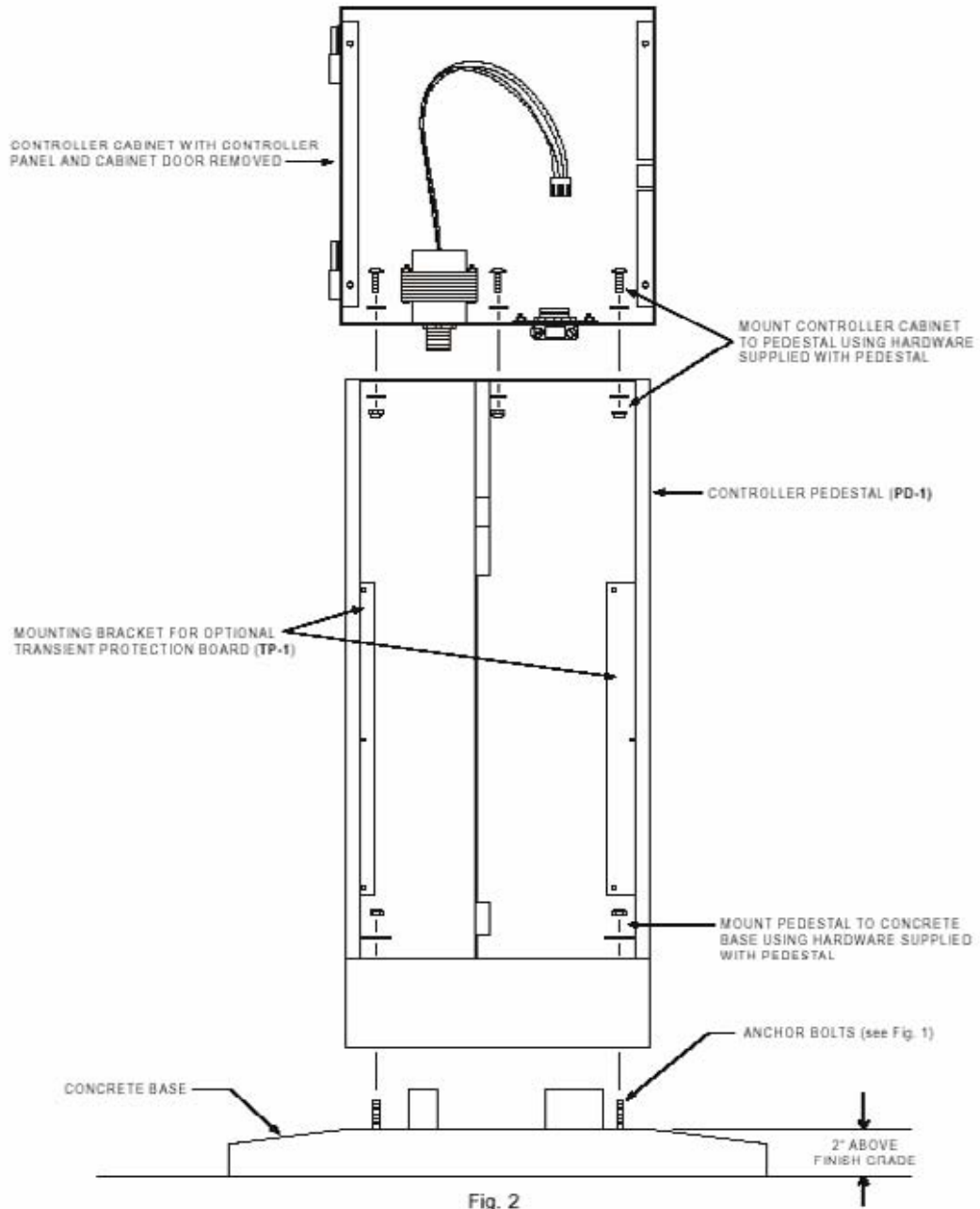

Fig. 2

**CALSENSE.**

2075 Corte del Nogal, Suite P  
Carlsbad, CA 92011  
(760) 438-0525, Fax (760) 438-2619  
www.calsense.com



**CALSENSE PRE-ASSEMBLED ENCLOSURE INSTALLATION DETAIL**

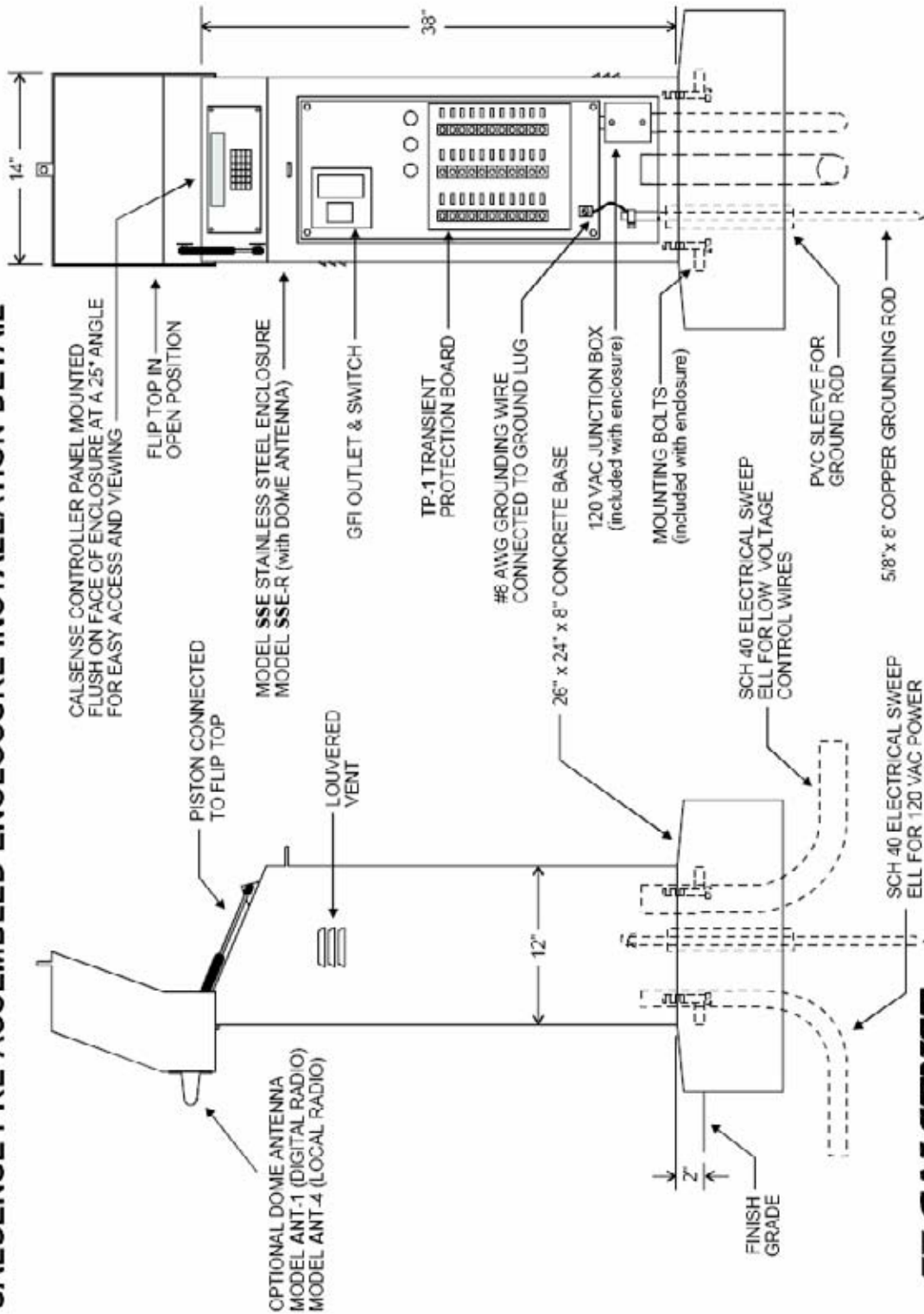

making water work

since 1986

## TRANSIENT PROTECTION BOARD & BOX INSTALLATION

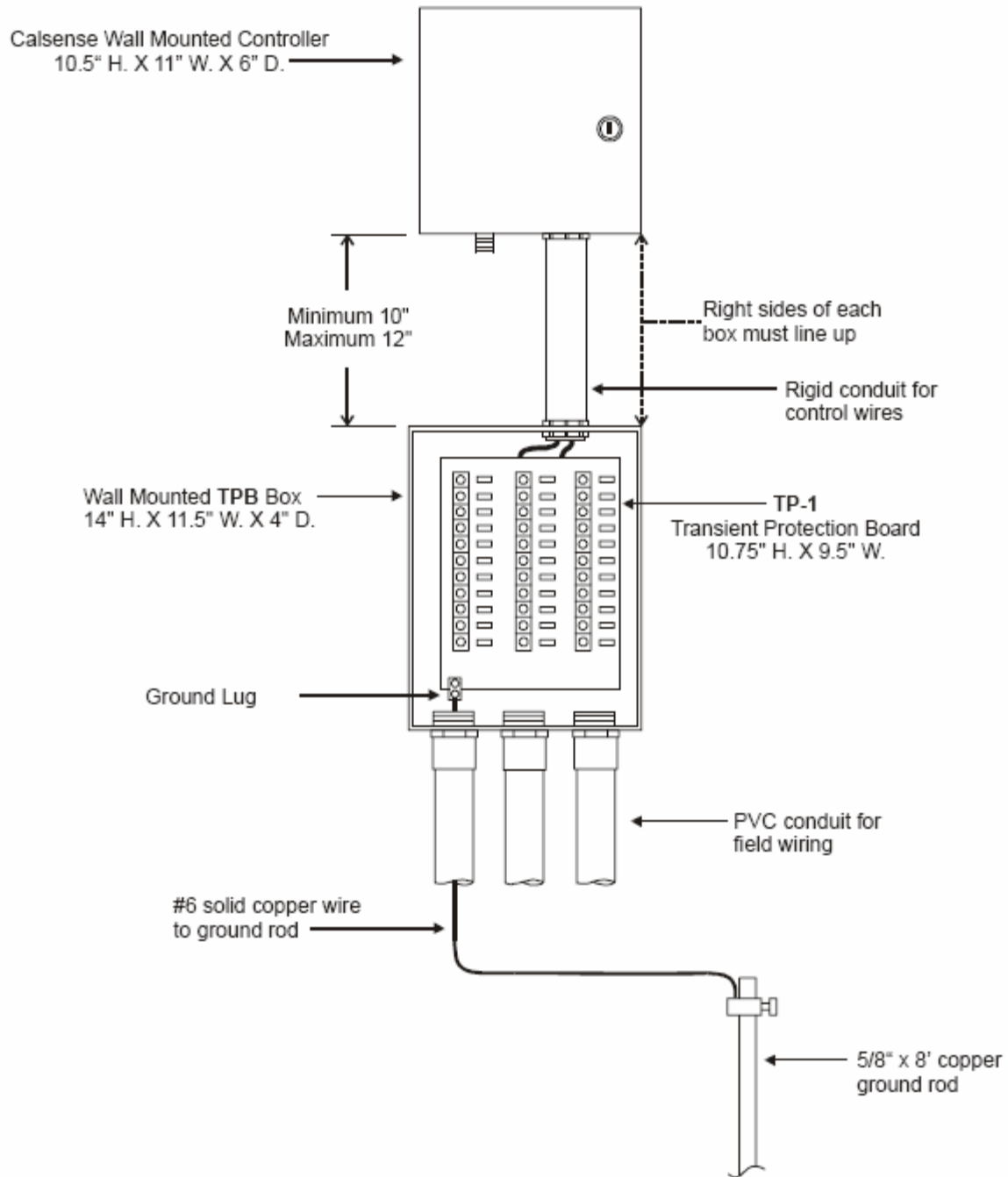

### CALSENSE SSBP STAINLESS STEEL BACKPLATE ASSEMBLY

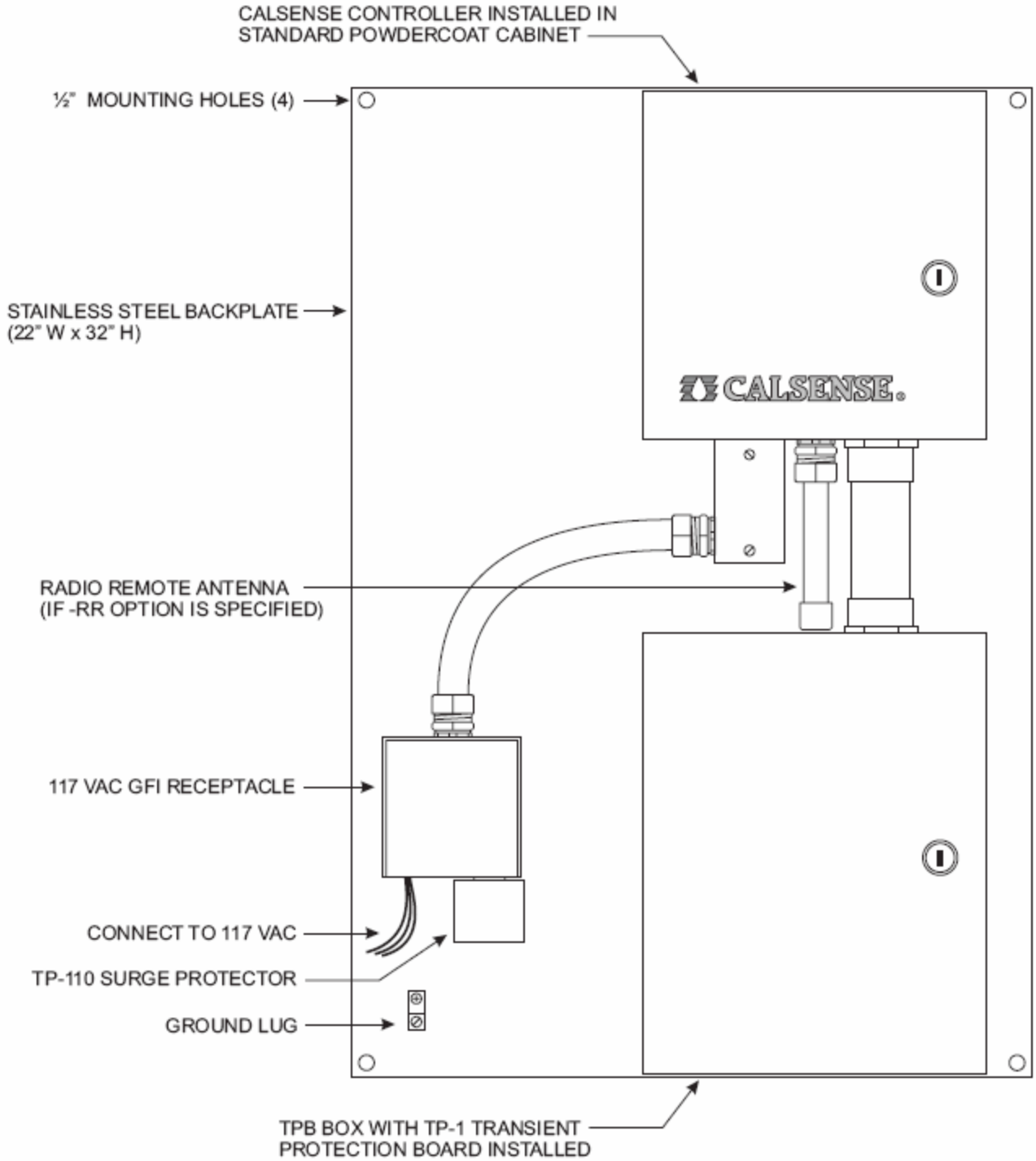

**Pedestal Mounting (SSE, SSE-R)**

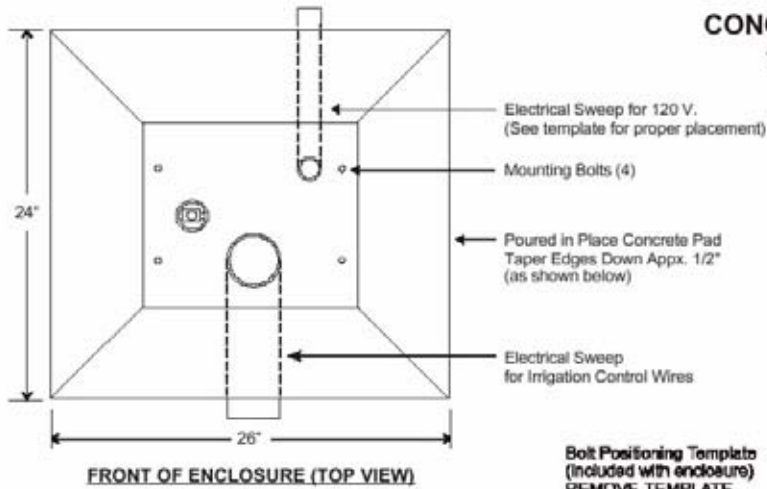

**CONCRETE PAD FOR SSE ENCLOSURE  
with Bolt Positioning Template**

**INSTRUCTIONS :**

Note: Bolt Positioning template should be REMOVED after concrete has cured for 24 hours.

1. Pour concrete pad onto minimum 3" of compacted base material. Top of concrete pad should be flat and level.
2. Push template with bolts attached into wet concrete until template touches the surface of wet concrete. Use bubble level sight gage to level template.
3. Edges of pad to be tapered down and away from level top surface to allow any water to drain away from enclosure (as shown below).
4. REMOVE BOLT POSITIONING TEMPLATE after concrete pad has cured for at least 24 hours and attach enclosure to bolts.

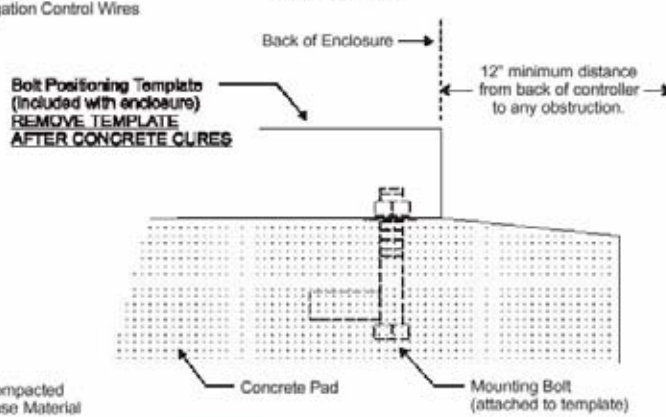
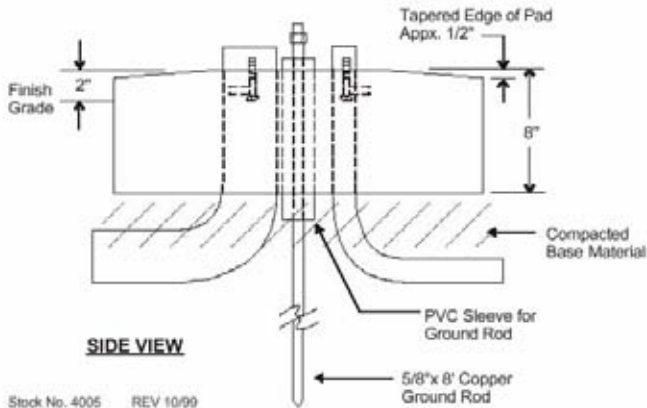

**IMPORTANT :**  
**REMOVE BOLT POSITIONING TEMPLATE  
BEFORE MOUNTING ENCLOSURE**

Stock No. 4005 REV 10/99



**Electrical Hookup**

**120 VAC Power Connections and Unit Grounding**

Perform all 120 VAC electrical and grounding hookup per local and national electric code.

- Connect the 120 VAC power line to the input wires of the transformer. Connect one side to the black wire and the other to the white wire.
- Enclose the 120 VAC power line in conduit approved for grounding and connect securely to the transformer nipple. The conduit is to be grounded and will serve as the controller ground.

**Station Wire Connections**

**CAUTION:**

**NEVER** touch station wires and field wires together while the station is activated (e.g. for identifying valves before wiring a controller). This could result in damage to the irrigation controller.

- Use the attached Station Wire Color Code chart to locate the correct color wire in the wiring harness and attach it to the station wire using wire nuts or terminal strips.
- Repeat this procedure for all stations.
- Connect both white wires on the black connector to field common and #6 ground wire as shown in the Grounding Instructions included with the controller.

**Loading Examples**

The following chart provides loading examples with remote control valves and relays.

**Note:** The total load must never exceed 1.5 amps. Also note not all solenoids draw .3 amps.

LOADING EXAMPLE CHART						
	STATION	STATION	STATION	MASTER VALVE	PUMP	TOTAL
Case 1	S			S	R	0.8A
Case 2	S	S		S	R	1.1A
Case 3	S	S	S	S	R	1.5A

**Notes:** S stands for a 0.3 A solenoid.  
 R stands for a 0.2A relay coil.  
 Any single output may be loaded to 1.5A.  
 The total load must never exceed 1.5A.



**Controller wiring instructions (PD-1)**

- Open cabinet door and remove the access panel below the controller front panel.
- The Class 1 wiring (117 volt line input) may be brought into the pedestal through a conduit placed in the concrete base.
- The Partition in the pedestal separates Class 1 and Class 2 wiring. The space on the right of the partition is for the Class 2 wiring (valve and wiring other than Class 1 wiring). It is not necessary to run conduit inside the pedestal.
- Follow the electrical hookup in the Model ET2000 and ET2000e Wiring Diagram sheet.

**Controller wiring instructions (SSE, SSE-R)**

- Bring 120 VAC line up to electrical 4 by 4 box via grounded conduit. Attach line voltage to black, white, and green wires.
- A 120 VAC safety ground must be attached to the GFI Ground terminal. Grounding must be per national and Local codes.
- For increased irrigation controller protection against lightning, a ground rod should be used. Portions of the extended warranty requires its use. Follow the Grounding Instructions on the Grounding Sheet provided with the controller. The lower left lug of the terminal strip board (Transient Protection Board TP-1) is for the grounding rod.

**Master valve (Blue wire)**

- The master valve wire from the irrigation controller provides a 24 VAC output to the master valve. Connect the master valve wire to the valve operating the main water supply using the same common wire as the other stations.

**Pump Start Signal (Green wire)**

- The green wire in the black wire harness can be used to operate a 24 VAC relay which turns on a pump. One side of the coil of the relay should be connected to the green wire of the black harness. The other side should be connected to field common.

- Do not use relays which draw power causing the total of all stations which can operate simultaneously and the pump start relay to exceed the 1.5A rating of the transformer.

**Remote Control (Orange wire)**

When connecting a Remote control interface cable, use the same station wires and common as connected to the field wires. The 24 volt wire on the Radio Remote interface cable should be connected to the orange wire on the black harness.

**Flow Meter (Red and Black wires)**

If a flow meter is used, it is to be connected to the red and black wires on the black harness. Make sure to connect the red wire from the controller to the red wire on the flow meter, and the black wire from the controller to the black wire on the flow meter. The flow meter connections must be watertight or the flow meter will not operate properly. **NEVER** use buried splices. **DO NOT** connect flow meter to 24 VAC or 12 VAC outputs.

**Rain Cups (Orange, White, Yellow wires)**

Rain Cups are normally used to break the common wire between the controller and the valves. DO NOT install the rain cup in this manner with Calsense irrigation controllers because it will disable some of the controllers features. Installation should be done according to the following diagram. Calsense recommends either the Mini-clip or the WCS 4 wire Rain Guard/ RG DCC which have mechanical switches.

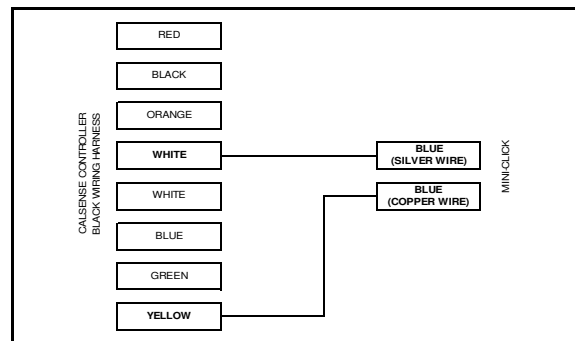

**Mini-clip wiring diagram**

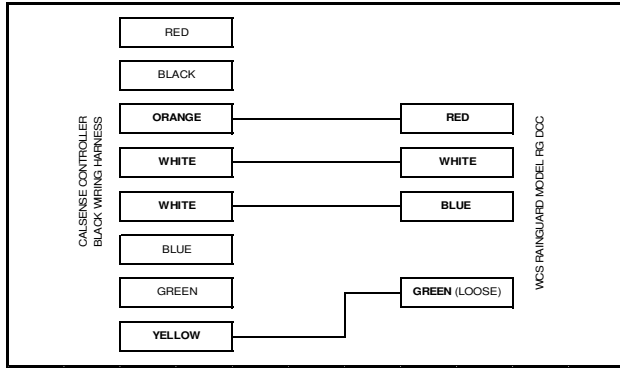

**WCS Rainguard model RG DCC wiring diagram**

**Installing the irrigation controller in the cabinet (2 Orange, 2 Blue wires)**

- First plug in the color coded connectors into the printed circuit board. The color of each connector is printed on the board, beneath it's plug. The size of the controller determines how many color coded connectors there will be. After all color coded connectors are in place, plug in the transformer power plug (The small white connector with two (2) orange and two (2) blue wires.

**CAUTION:**

When installing the connectors please note that they only go on one way. Do not attempt to force them on upside down.

- Next put the irrigation controller in the cabinet and secure it with the four (4) mounting screws.

**System Check out**

Before operating the stations from the irrigation controller, it is suggested that all the wires be checked for proper connections. If station flow rates and moisture sensor measurements are to be checked then use either the TEST or MANUAL key. Refer to the instruction sheet located inside the door of the controller to operate MANUAL or TEST modes.

**Moisture Sensor Installation**

Please call the factory at 1-(800)-572-8608 for assistance in sensor placement and operation.

**Grounding Instructions**

**NON-LIGHTNING PRONE AREAS**

**Stand Alone System:**

- Stand alone systems in non-lightning prone areas require no ground rod. The case of the controller must be grounded from the conduit nipple of the transformer to earth or safety ground in accordance with the local or National Electrical Code.
- Stand alone systems are defined as individual controllers installed and connected only to valves and sensors. If multiple controllers are connected together in any way, such as but not limited to sharing Master Valves, Flow Meters, or communications, this is not a stand alone system. The only exception is that stand alone controllers may share the same AC power line wiring.

**Central Communications or Shared Systems (Non-Stand Alone):**

- Install one 5/8 inch by 8 foot grounding rod per irrigation controller (see diagram). Do not connect multiple controllers to the same ground rod. The top of each rod must be installed inside of a 10 inch round valve box. If a pedestal is being mounted, the ground rod may be installed through the pedestal base. The ground rod should be installed as close as practical to the controller. Under no circumstances shall the rods be shortened.
- Use brass clamps specifically designed to secure the copper wire to the grounding rods. Sand both the rod and the inside of the clamp to remove all oxide from the contact surfaces.
- Connect a #6 AWG solid copper wire from the copper rod to the field common (white wires in the black harness) of the controller.

**WARNING:**

Never connect the ground rod or the white wire (field common) to the Black wire (Flow return) of the black wiring harness. This will disable the over current protection, and could result in damage to the controller. There should be no kinks or sharp bends in the wire.

**LIGHTNING PRONE AREAS*****All Systems, Stand Alone and Central Communications systems:***

- Install one 5/8 inch by 8 foot grounding rod, one TP-1 Transient Protection Board, and one TP-110 Surge Protector per irrigation controller (see diagram). Do not connect multiple controllers to the same round rod. The top of each rod must be installed inside of a 10 inch round valve box. If a pedestal is being mounted, the ground rod may be installed through the pedestal base. The ground rod should be installed as close as practical to the controller. Under no circumstances shall the rods be shortened.
- Use brass clamps specifically designed to secure the copper wire to the grounding rods. Sand both the rod and the inside of the clamp to remove all oxide from the contact surfaces.
- Connect a #6 AWG solid copper wire from ground lug of the TP-1 to the copper rod. There should be no kinks or sharp bends in the wire.
- As an alternate to clamping, each wire may be wrapped around the rod and brazed in place. Braze the wire to the rod for at least one circumference of the rod.

***Lightning Warranty***

- This standard warranty will be extended to cover lightning damage if the controller and / or central system is installed in accordance with our installation instructions for each item installed, the National Electrical Code, and these grounding instructions.

**Grounding Instructions Diagram**

**NON-STAND ALONE  
NON-LIGHTNING PRONE AREAS**

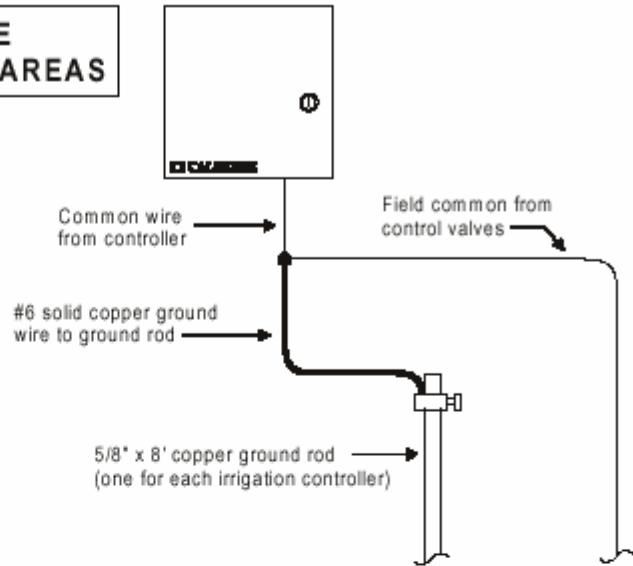

**ALL SYSTEMS  
LIGHTNING PRONE AREAS**

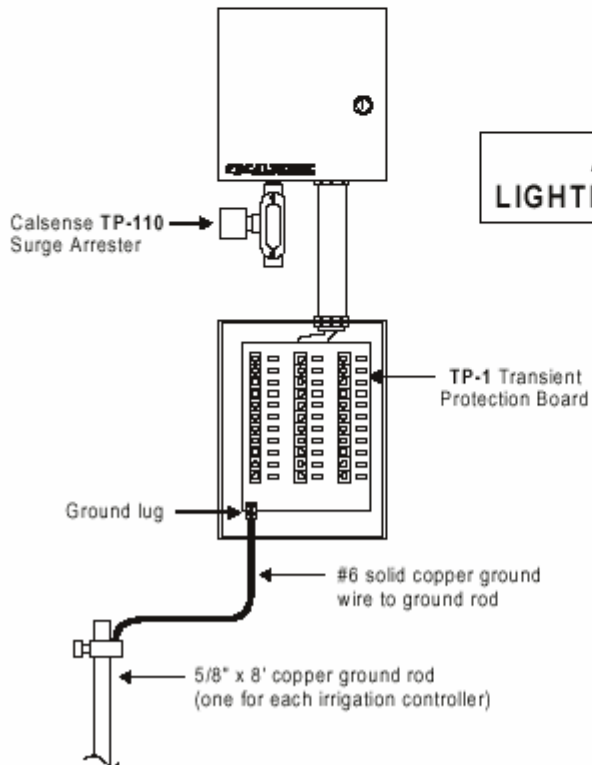



**ADDITIONAL IRRIGATION CONTROLLER OPTIONS**

**Multiple Flow Meter Interface (-F option)**

Calsense Irrigation Controllers can receive up to three (3) separate flow inputs with projects consisting of more than one water source for irrigation landscape. However the irrigation controller must be specified with the -F option. The first flow meter is wired to the irrigation controller as described in the Flow Meter installation Instructions. The second and third Flow Meters are wired to the irrigation controller using the additional (-F) Flow Meter cable. Use the following diagram:

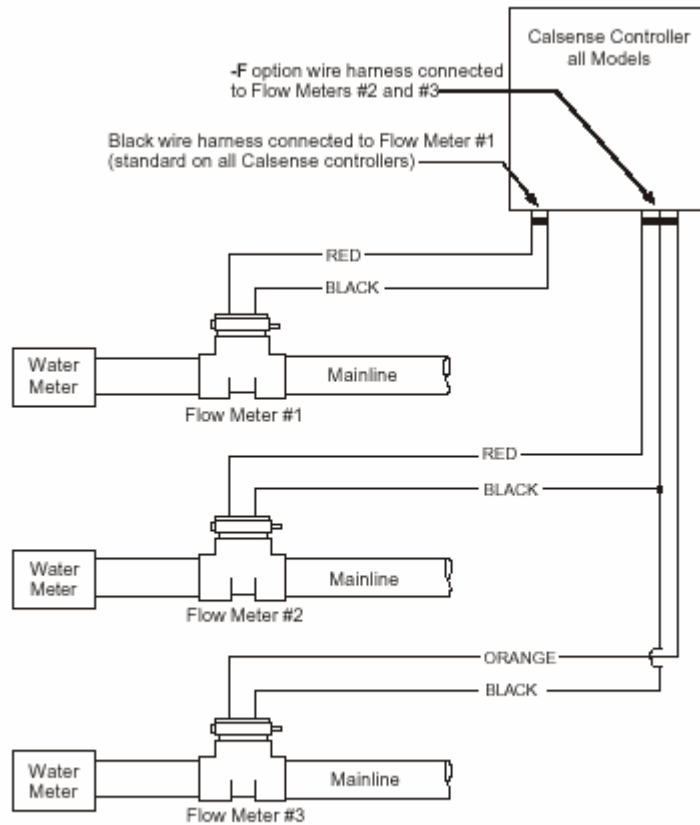

**-F WIRING DIAGRAM**

**ET Gage Interface (-G option)**

Refer to the ET Gage Installation Instructions provided with every ET Gage.

**Rain Bucket Interface (-RB option)**

Refer to the Rain Bucket Installation Instructions provided with every Rain Bucket.

**Wind Gage Interface (-WG option)**

Refer to the Wind Gage Installation Instructions provided with every Wind Gage.

**CENTRAL COMMUNICATION**

**☹ Phone Modem Communications (-M and -M-R options)**

When several irrigation controllers are sharing one phone line, they are known as a chain of - M controllers. The M stands for multiple controller communication system. A modem (MOD-1) and a line amplifier (LA-2), are two (2) additional pieces of equipment which comprise the system. On units shipping after 1999, the controller when specified with a -M-R option comes with the MOD-1 and LA-2 Integrated onto the controller board.

The controllers with a - M or - M-R option have a 3 wire (22 AWG) cable. This cable is used to connect the communication system to the single phone line. Use Paige P-7171-D cable **in conduit** to connect one irrigation controller to the next.

If a Transient Protection Board (TP-1) is used with the irrigation controller, connect the green wire from the line amplifier (LA-2) pigtail and the - M irrigation controller pigtail to one of the terminals labeled FIELD COMMON on the board. Connect the yellow wire from both line amplifier and - M pigtails to the terminal labeled SHIELD.

**Note:** Older controllers may require a different wiring diagram, contact Calsense at 1-(800)-572-8608 for more information.

**-M-R COMMUNICATION CABLE WIRING DIAGRAM**

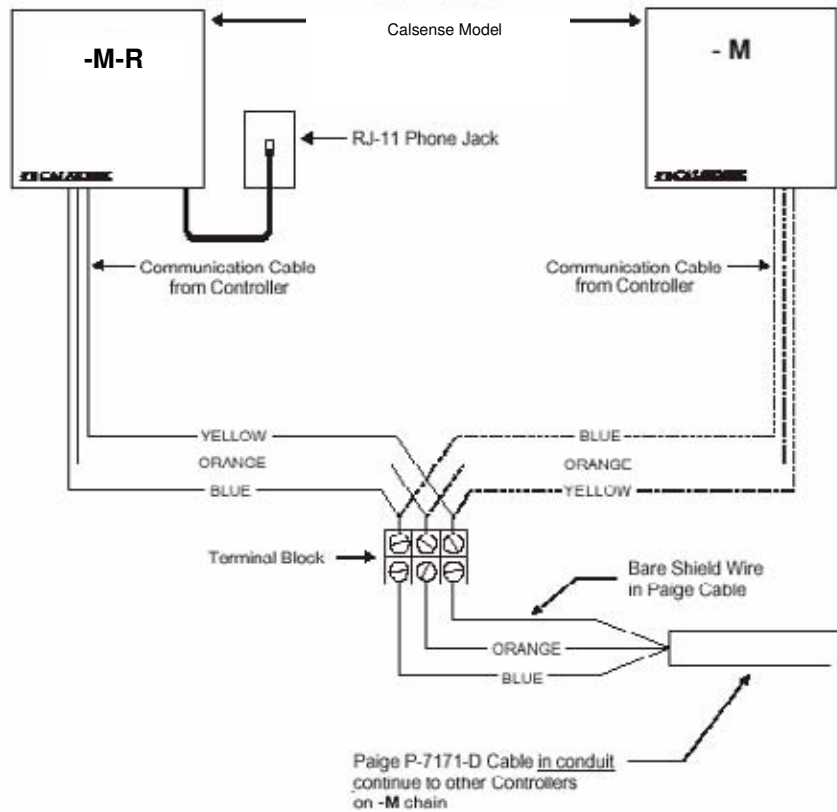

**CENTRAL COMMUNICATION**

**Non-Hardwired- -to Hardwired Communication (-M-LR, -M-CR, -M-SR, -M-EN, -M-GR, -M-FOM, to a - M option)**

Several irrigation controllers can share one Communications device. The irrigation controller which has the communications device is designated with a -M plus the two letter communications option. The Communications device is powered by the controller panel. All other irrigation controllers which are to be linked to the Communications irrigation controllers are specified as - M's.

The Communications irrigation controller comes with a coaxial antenna cable. This cable is simply screwed into the dome antenna mounted on top of the enclosure or irrigation controller cabinet (see mounting instructions included with antenna).

Paige P-7171-D cable is used to link the Communications irrigation controller(s) to the one - M. The maximum number of - M irrigation controllers linked in a chain is 31. The maximum length of cable is 5,000 feet. Follow the diagram below for proper wiring of the Paige cable to the irrigation controller.

**COMMUNICATIONS CABLE WIRING DIAGRAM**

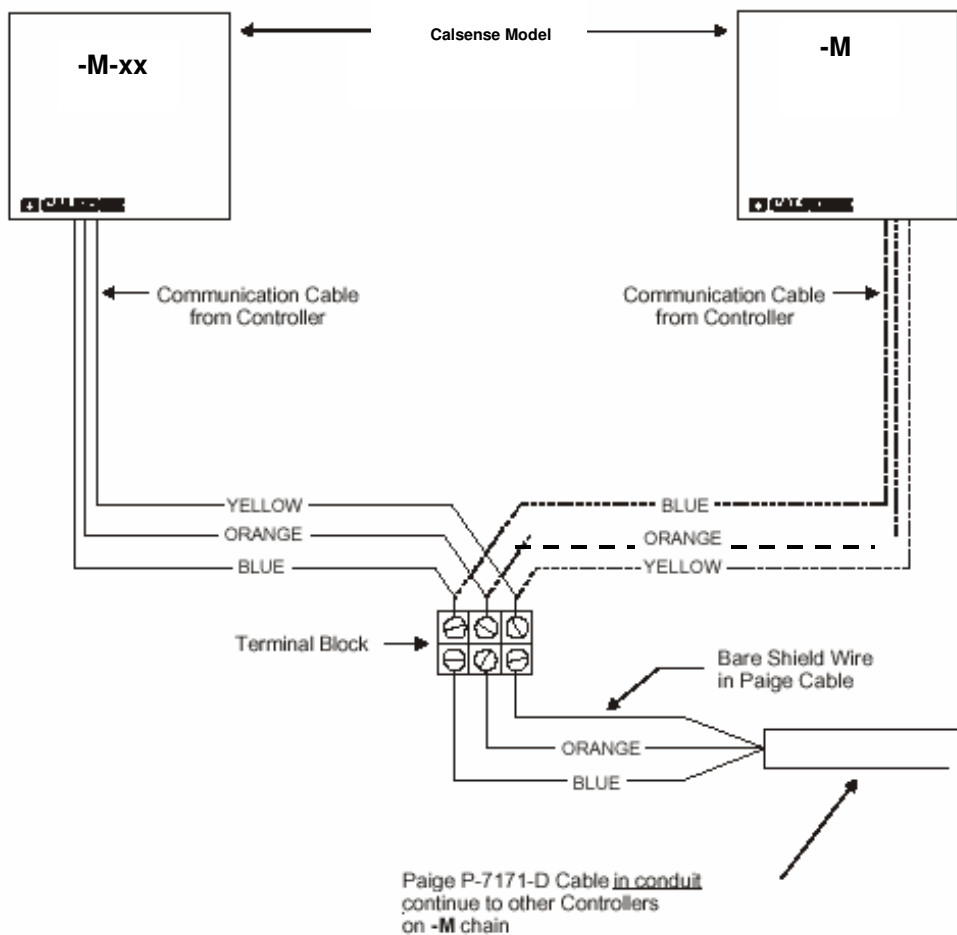

**STATION COLOR WIRE CODE**



STATION	CONNECTOR COLOR	WIRE COLOR	STATION	CONNECTOR COLOR	WIRE COLOR
1	RED	BLACK	33	WHITE	BLACK
2	RED	RED	34	WHITE	RED
3	RED	WHITE	35	WHITE	WHITE
4	RED	GREEN	36	WHITE	GREEN
5	RED	ORANGE	37	WHITE	ORANGE
6	RED	BLUE	38	WHITE	BLUE
7	RED	BROWN	39	WHITE	BROWN
8	RED	YELLOW	40	WHITE	YELLOW
9	BLUE	BLACK	41	BROWN	BLACK
10	BLUE	RED	42	BROWN	RED
11	BLUE	WHITE	43	BROWN	WHITE
12	BLUE	GREEN	44	BROWN	GREEN
13	BLUE	ORANGE	45	BROWN	ORANGE
14	BLUE	BLUE	46	BROWN	BLUE
15	BLUE	BROWN	47	BROWN	BROWN
16	BLUE	YELLOW	48	BROWN	YELLOW
17	YELLOW	BLACK	<b>LIGHTS</b>	<b>CONNECTOR COLOR</b>	<b>WIRE COLOR</b>
18	YELLOW	RED	L1	ORANGE	WHITE
19	YELLOW	WHITE	L2	ORANGE	GREEN
20	YELLOW	GREEN	L3	ORANGE	ORANGE
21	YELLOW	ORANGE	L4	ORANGE	BLUE
22	YELLOW	BLUE			
23	YELLOW	BROWN			
24	YELLOW	YELLOW			
25	GREEN	BLACK	<b>FUNCTION</b>	<b>CONNECTOR COLOR</b>	<b>WIRE COLOR</b>
26	GREEN	RED	FLOW IN	BLACK	RED
27	GREEN	WHITE	FLOW OUT	BLACK	BLACK
28	GREEN	GREEN	24 VAC	BLACK	ORANGE
29	GREEN	ORANGE	COMMON	BLACK	WHITE
30	GREEN	BLUE	COMMON	BLACK	WHITE
31	GREEN	BROWN	MASTER VALVE	BLACK	BLUE
32	GREEN	YELLOW	PUMP	BLACK	GREEN
			RAIN SWITCH INPUT	BLACK	YELLOW

**DO NOT SHORT OUTPUTS - SEVERE DAMAGE MAY RESULT**

DATE SEP 2005 Version B Controller Output Label

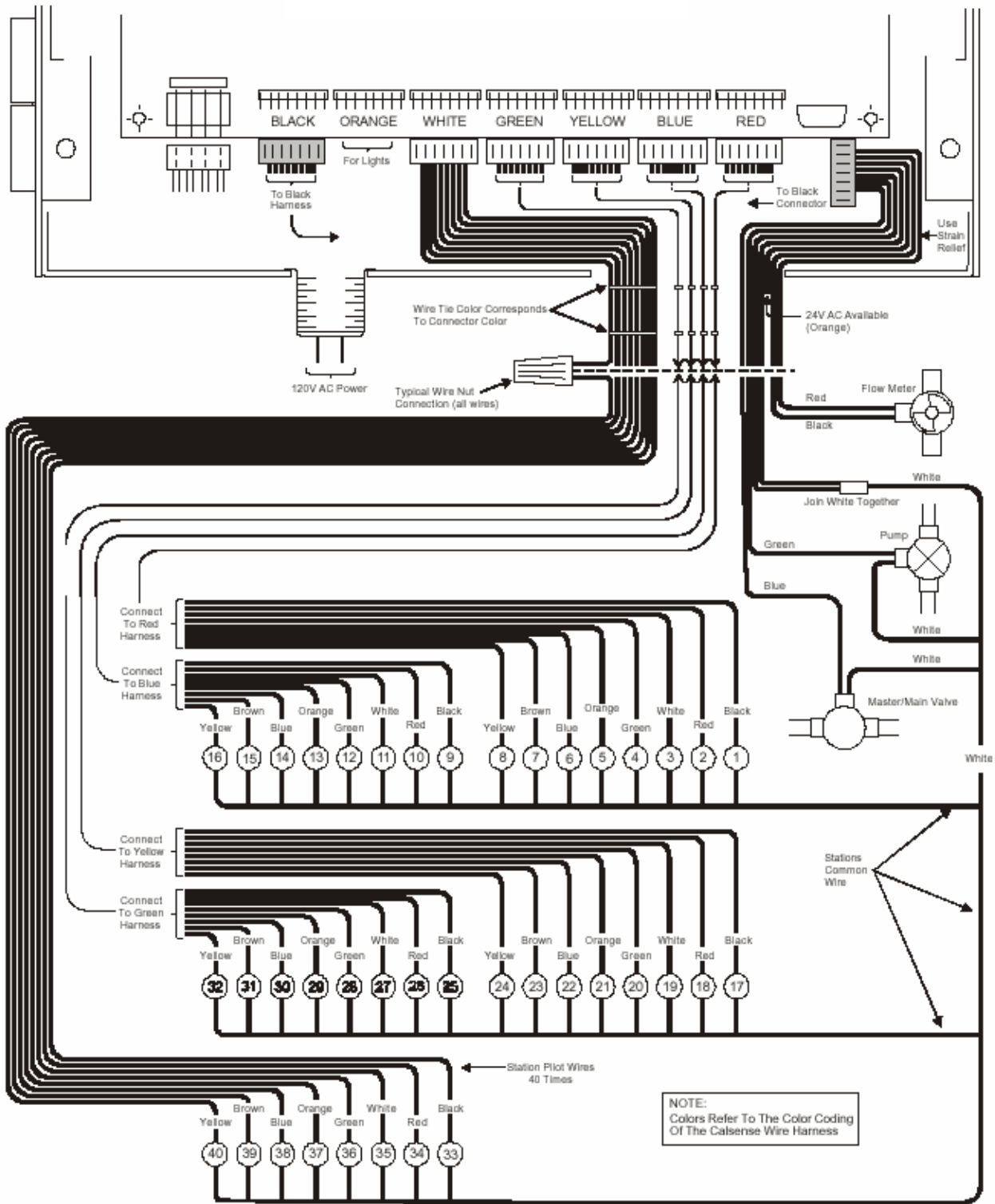

**MODEL ET2000 Wiring Diagram**





 **OPTIONS GUIDELINE CHART**

OPTION GUIDELINE CHART				
EQUIPMENT	WIRE GAGE	MAX NUMBER ALLOWED	MAXIMUM DISTANCE	REMARKS
Controller(s) Non-Hardwired	N/A	Max number of controllers assigned to one HUB is as many Communication address combinations that are possible	Depends on the type of communications used:	N/A
Controller(s) Hardwired	Paige P-7171-D	31 controllers maximum	5000 foot total	N/A
Flow Meter	Standard #14 AWG	One Flow Meter per controller unless the (-F) option is used then three max per controller.	2000 foot uninterrupted	Must be unrestricted pipe 10 times diameter upstream, 5 times pipe diameter downstream.
Master valve	Standard #14 AWG	One Master Valve Per Controller	N/A	N/A
Pump	Standard #14 AWG	One Pump Per Controller	N/A	N/A
Station Valve	Standard #14 AWG	Limited to maximum Station slots on controller	N/A	N/A
Moisture Sensor	Standard #14 AWG	One per station valve.	3000 foot uninterrupted wiring.	Contact Calsense for proper placement and installation.
ET Gage	Paige P-7171-D 18 Gage multi-conductor irrigation wire may be substituted, if under 100 feet.	One ET Gage hardwired to 12 controllers max. Non-Hard wired no limit	1000 foot on one hardwired chain.	Controller ET Gage is wired to must have - G option. If hardwired to multiple controllers all controllers in chain must have - G option or - FL option
Rain Bucket	Paige P-7171-D	One Rain Bucket to 12 controllers max. Non-Hardwired no limit	Max cable run is 200 feet	Controller Rain Bucket is wired to must have - RB option. If hardwired to multiple controllers all controllers in chain must have - G option or -FL option
Wind Gage	Paige P-7171-D	One Wind Gage 12 controllers max. Wind cannot be shared to non-Hardwired controllers unless -FL option is used.	Max cable run is 200 feet	Controller Wind Gage is wired to must have - WG option. If Hard wired controllers must have -FL option.



**2075 Corte del Nogal, Suite P, Carlsbad CA 92011**  
**1-(800)-572-8608 FAX: 1-(760)-438-2619**  
**[www.calsense.com](http://www.calsense.com)**

Stock Number: PG2-IC-C

Rev. 01/06



**making water work**

**since 1986**